

# ***P* PLUSIVO**

## ***Mastering The Art of Measurement (Clamp Meter)***

## Table of Contents

<b>Introduction</b>	<b>3</b>
<b>1. Overview</b>	<b>3</b>
1.1 Versions of the clamp meter	3
1.2 Parts	4
1.3 Rotary switch	5
1.4 Key function description	6
1.5 LCD Display	7
<b>2. Features</b>	<b>8</b>
<b>3. Safety Notes</b>	<b>9</b>
<b>4. Reference Table</b>	<b>9</b>
4.1 Table of SI units	9
4.2 Table of prefixes	10
<b>5. General Characteristics</b>	<b>10</b>
5.1 AC current parameters	10
5.2 DC current parameters (CL101C only)	11
5.3 DC voltage	11
5.4 AC voltage	11
5.5 Frequency	12
5.6 Duty cycle	12
5.7 Via gear frequency	12
5.8 Clamp frequency measurement (Via gear A)	12
5.9 Via gear V	12
5.10 Resistance	13
5.11 Continuity test	13
5.12 Capacitance	13
5.13 Temperature	14
5.14 Low impedance measurement	14
<b>6. Measurement</b>	<b>15</b>
6.1 DC Voltage Measurement	15
6.2 AC Voltage Measurement	16
6.3 AC Current Measurement	17
6.4 DC Current Measurement	18
6.5 Resistance Measurement	20
6.6 Capacitance Measurement	22
6.7 Diode Test	24
6.8 Continuity Test	26
6.9 Temperature measurement	27
6.10 Frequency measurement	28

6.11 Frequency measurement using the clamp	29
6.12 Duty cycle measurement	30
6.13 MAX/MIN measurement	31
6.14 REL (relative) measurement	33
6.15 LoZ (low impedance) measurement	36
6.16 NCV Detection	38
<b>7. Basic Concepts</b>	<b>39</b>
7.1 Ohm's Law	39
7.1.1 Example	39
7.2 Joule's Law for Electrical Power	42
7.2.1 Example	42
7.3 Kirchhoff's Law	44
7.3.1 Kirchhoff's Current Law	44
7.3.2 Kirchhoff's Voltage Law	44
7.3.3 Example	45
7.4 Shunt resistor	50
7.4.1 Example	51
7.5 Choosing the Right Resistor for an LED	53
7.5.1 Example	54
7.6 Measuring Internal Resistance of a Battery	55
7.6.1 Example	56
7.7 Testing Some Components Using clamp meter	58
7.7.1 Potentiometer Test	58
7.7.2 BJT Transistor Test	60

## Introduction

In this guide, you are going to learn how to measure DC-AC voltage, DC-AC current, resistance, diodes, capacitance, frequency, duty cycle, MAX/MIN measurement, REL (relative) measurement, LoZ (low impedance) measurement, NCV measurement, temperature and continuity test using clamp meter. We are going to study some basic concepts like Ohm's Law and Kirchhoff's Law.

Let's get started!

## 1. Overview

### 1.1 Versions of the clamp meter

There are two versions of this clamp meter which are CL101B and CL101C.

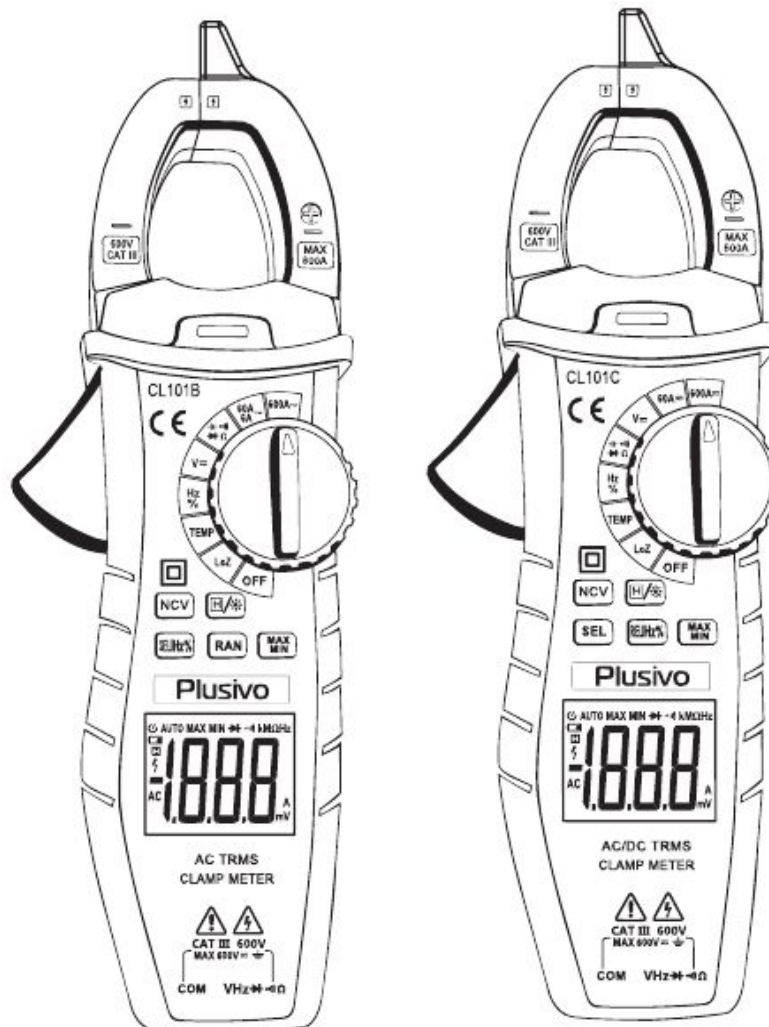

The main difference between them is that the current clamp in version **CL101C** can measure **DC-AC current**, but the current clamp in version **CL101B** can measure only **AC current**.

## 1.2 Parts

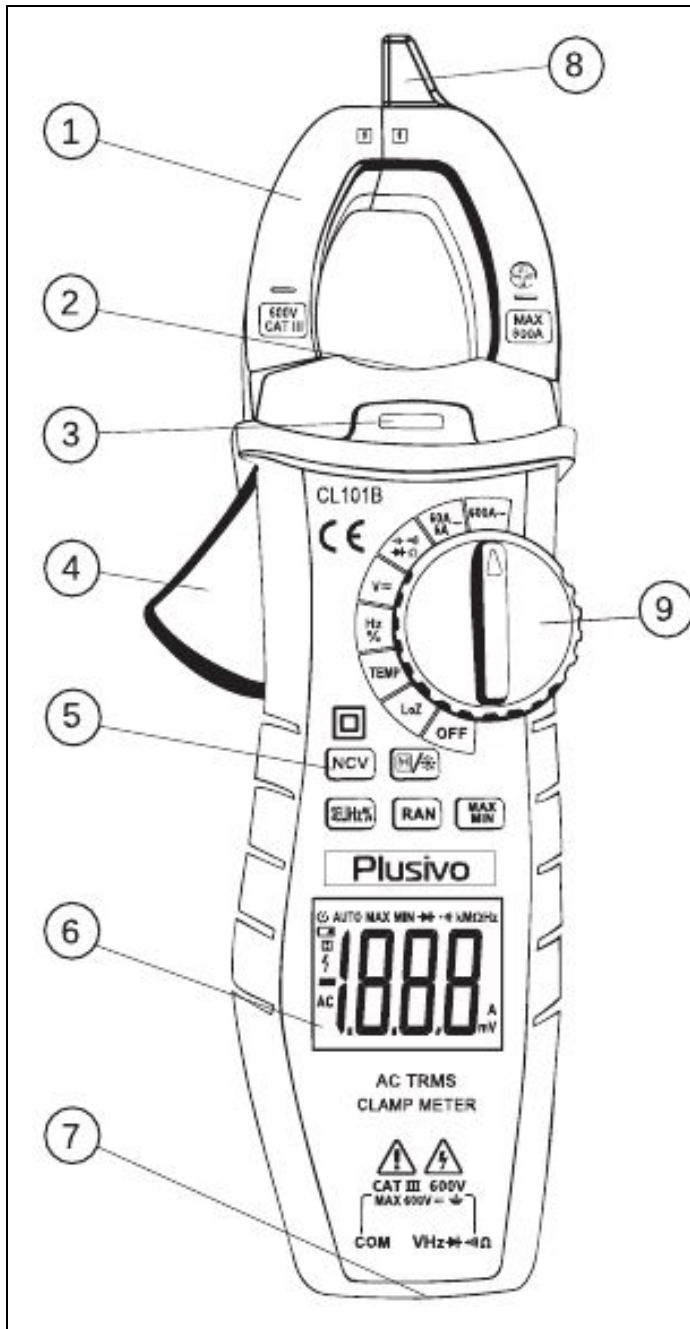

- (1) Current clamp
- (2) Flash light
- (3) Alarm indicator light
- (4) Trigger for opening the current clamp
- (5) Function key
- (6) LCD (Liquid Crystal Display)
- (7) Test probes connection sockets
- (8) Non contact voltage detector
- (9) Rotary switch

## 1.3 Rotary switch

Below you can see functions of the rotary switch for both versions.

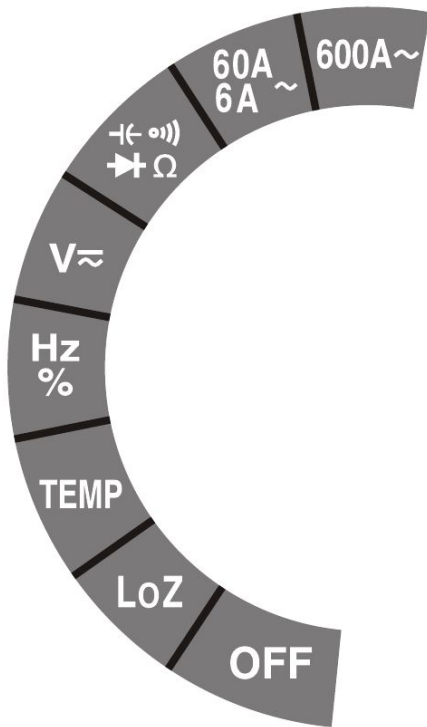

**CL101B**

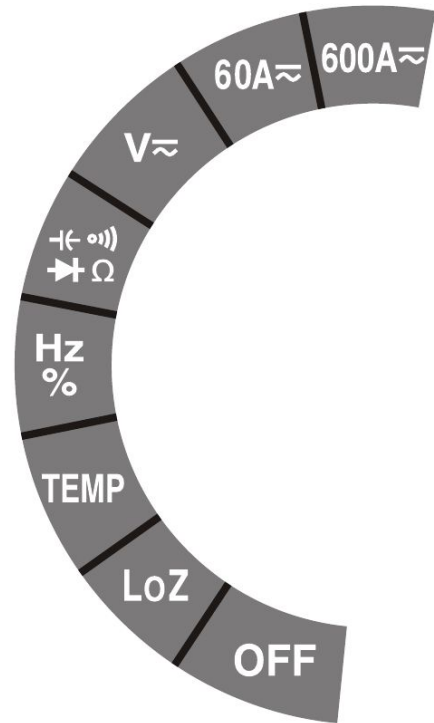

**CL101C**

<b>600A ~</b>	AC current measurement up to 600 A
<b>60A ~ 6A ~</b>	AC current measurement up to 60 A / 6 A
<b>600A ≈</b>	AC-DC current measurement up to 600 A
<b>60A ≈</b>	AC-DC current measurement up to 60 A
<b>TEMP</b>	Temperature measurement
<b>V ≈</b>	AC-DC voltage measurement
<b>⎓ (⊖) ⊕ ➔ Ω</b>	Capacitance / Continuity / Resistance / Diode
<b>LoZ</b>	Low impedance voltage measurement
<b>Hz%</b>	Frequency measurement - Duty cycle measurement
<b>OFF</b>	Instrument turned OFF





## 1.4 Key function description





### CL101B Buttons



### CL101C Buttons

	Non contact voltage detection
	Hold function / backlight and flashlight
	Select function
	Change range
	Maximum / Minimum value measurement mode





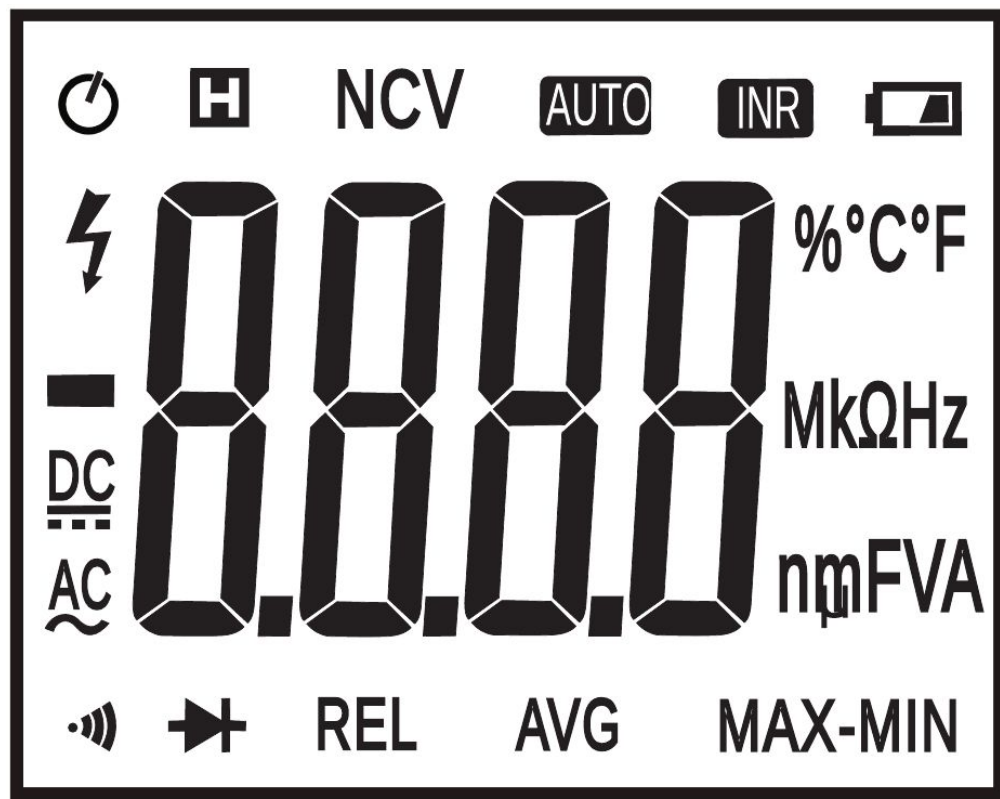

	Relative measurement / Frequency measurement - Duty cycle measurement
	Select function / Frequency measurement - Duty cycle measurement

**Note:** flashlight only works during current measurement.



## 1.5 LCD Display



	Alternating current measurement
	Direct current measurement
	Auto-range mode
	Auto power off indicator
	Low battery
	Hold function activated
<b>V</b>	Voltage measurement (mV, V)
<b>A</b>	Current measurement
<b>Hz</b>	Frequency (Hz, kHz)
<b>MAX-MIN</b>	Maximum and minimum value
<b>F</b>	Capacitance (nF, $\mu$ F)
<b>%</b>	Duty cycle measurement
<b>REL</b>	Relative measurement

## 2. Features

- Automatic selection of the measurement function and range
- Overload protection through the whole range
- Maximum voltage between the measurement probe and ground: 600V DC or 600V AC
- Maximum operating height of 2000 m
- LCD display
- Maximum display of "OL" or "-OL"
- Overload protection through the whole range
- Sampling rate of 3 times per second

- Function and measurement unit display
- Maximum display value of 6000 counts
- Automated polarity indication
- Auto power off after 15 minutes
- Power supply from 3 x 1.5V AAA batteries
- Low battery detection
- Temperature coefficient of less than 0.1 x accuracy / °C
- Operating temperature range: 18°C ~ 28°C
- Storage temperature range: 10°C ~ 50°C

## 3. Safety Notes

1. When using this instrument please observe the standard safety rules:
  - General electric shock prevention
  - Instrument misuse prevention rules
2. Before using this instrument check whether it has been damaged during transportation or storage.
3. Before use, check whether the insulation of the test probes has been damaged and whether the wire conductor is exposed, the test probes must be in good condition.

In general, if something unusual happens or if you suspect that something is wrong or has malfunctioned, do not do anything with the product and immediately contact the seller for assistance (email address: [office@plusivo.com](mailto:office@plusivo.com))

## 4. Reference Table

### 4.1 Table of SI units

Quantity	SI Unit	Abbreviation
Voltage	Volts	V
Current	Ampere	A
Power	Watt	W
Energy	Joule	J
Electric charge	Coulomb	C
Resistance	Ohm	Ω
Capacitance	Farad	F
Inductance	Henry	H
Frequency	Hertz	Hz

## 4.2 Table of prefixes

Prefix	Power	Numeric Representation
Tera (T)	$10^{12}$	1 trillion
Giga (G)	$10^9$	1 billion
Mega (M)	$10^6$	1 million
Kilo (k)	$10^3$	1 thousand
No prefix	$10^0$	1 unit
Milli (m)	$10^{-3}$	1 thousandth
Micro (u)	$10^{-6}$	1 millionth
Nano (n)	$10^{-9}$	1 billionth
Pico (p)	$10^{-12}$	1 trillionth

## 5. General Characteristics

### 5.1 AC current parameters

Range	Resolution	Accuracy
60 A	0.01 A	± (2.5% reading + 8 digits)
600 A	0.1 A	± (2.5% reading + 8 digits)

<b>Minimum input AC current</b>	0.1 A
<b>Maximum input AC current</b>	600 A
<b>Frequency range</b>	45 ~ 400 Hz

## 5.2 DC current parameters (CL101C only)

Range	Resolution	Accuracy
60 A	0.01 A	± (3% reading + 8 digits)
600 A	0.1 A	± (3% reading + 8 digits)

<b>Minimum input DC current</b>	0.1 A
<b>Maximum input DC current</b>	600 A

## 5.3 DC voltage

Range	Resolution	Accuracy
600 mV	0.1 mV	± (0.5% reading + 5 digits)
6 V	0.001 V	± (0.5% reading + 5 digits)
60 V	0.01 V	± (0.5% reading + 5 digits)
600 V	0.1 V	± (0.5% reading + 5 digits)

<b>Minimum input DC voltage</b>	0.001 V
<b>Maximum input DC voltage</b>	600 V

## 5.4 AC voltage

Range	Resolution	Accuracy
6 V	0.001 V	± (0.8% reading + 5 digits)
60 V	0.01 V	± (0.8% reading + 5 digits)
600 V	0.1 V	± (0.8% reading + 5 digits)

<b>Minimum input AC voltage</b>	0.01 V
<b>Maximum input AC voltage</b>	600 V
<b>Frequency range</b>	45 ~ 1000 Hz

## 5.5 Frequency

Range	Resolution	Accuracy
10 Hz	0.001 Hz	± (1% reading + 5 digits)
100 Hz	0.01 Hz	± (1% reading + 5 digits)
1000 Hz	0.1 Hz	± (1% reading + 5 digits)
10 kHz	0.001 kHz	± (1% reading + 5 digits)
100 kHz	0.01 kHz	± (1% reading + 5 digits)
1000 kHz	0.1 kHz	± (1% reading + 5 digits)
10 MHz	0.001 MHz	± (3% reading + 5 digits)

## 5.6 Duty cycle

Range	Resolution	Accuracy
1 ~ 99 %	0.1%	± (3% reading + 5 digits)

## 5.7 Via gear frequency

Measurement range	40 ~ 1000 Hz
Input signal range	≥ 0.2 ~ 10 V AC
Overload protection	250 V AC or DC

## 5.8 Clamp frequency measurement (Via gear A)

Measurement range	40 ~ 1000 Hz
Input signal range	≥ ¼ full scale value

## 5.9 Via gear V

Measurement range	40 ~ 1000 Hz
Input signal range	≥ 0.5 ~ 600 V AC

## 5.10 Resistance

Range	Resolution	Accuracy
600 $\Omega$	0.1 $\Omega$	$\pm$ (0.8% reading + 3 digits)
6 k $\Omega$	0.001 $\Omega$	$\pm$ (0.8% reading + 3 digits)
60 k $\Omega$	0.01 k $\Omega$	$\pm$ (0.8% reading + 3 digits)
600 k $\Omega$	0.1 k $\Omega$	$\pm$ (0.8% reading + 3 digits)
6 M $\Omega$	0.001 M $\Omega$	$\pm$ (0.8% reading + 3 digits)
60 M $\Omega$	0.01 M $\Omega$	$\pm$ (0.8% reading + 3 digits)

<b>Overload protection</b>	250 V AC or DC
----------------------------	----------------

## 5.11 Continuity test

If the resistance being measured is less than 50  $\Omega$  the instrument will emit a continuous alarm sound.

The resolution for the continuity test resistance measurement is 1  $\Omega$ .

The voltage overload protection for this function is up to 250 V AC or DC.

## 5.12 Capacitance

Range	Resolution	Accuracy
60 nF	0.01 nF	$\pm$ (4% reading + 3 digits)
600 nF	0.1 nF	$\pm$ (4% reading + 3 digits)
6 $\mu$ F	0.001 $\mu$ F	$\pm$ (4% reading + 3 digits)
60 $\mu$ F	0.01 $\mu$ F	$\pm$ (4% reading + 3 digits)
600 $\mu$ F	0.1 $\mu$ F	$\pm$ (4% reading + 3 digits)
6 mF	0.001 mF	$\pm$ (4% reading + 3 digits)
60 mF	0.01 mF	$\pm$ (4% reading + 3 digits)

<b>Overload protection</b>	250 V AC or DC
----------------------------	----------------

## 5.13 Temperature

Range	Resolution	Accuracy
-200 ~ 1300 °C	1 °C	± (1% reading + 2 °C)
-328 ~ 2372 °F	2 °F	± (1% reading + 4 °F)

<b>Overload protection</b>	250 V AC or DC
----------------------------	----------------

**Note:** The precision does not include the error of the thermocouple probe.

## 5.14 Low impedance measurement

Range	Resolution	Accuracy
6 V	0.001 V	± (0.8% reading + 5 digits)
60 V	0.01 V	± (0.8% reading + 5 digits)
600 V	0.1 V	± (0.8% reading + 5 digits)

<b>Minimum input AC voltage</b>	0.01 V
<b>Maximum input AC voltage</b>	600 V
<b>Frequency range</b>	45 ~ 1000 Hz

<b>Overload protection</b>	250 V AC or DC
----------------------------	----------------

**Note:** In low impedance measurement mode, the longest measurement time shall not exceed 1 minute.

## 6. Measurement

### 6.1 DC Voltage Measurement

1. Insert the black wire to "COM" and the red wire to VHz  $\cdot$   $\rightarrow$   $\Omega$  port.
2. Turn the rotary switch to AC and DC voltage measurement function.
3. Press the "SEL" key to select DC voltage measurement.
4. Connect the probes to the voltage that you want to measure (the red probe needs to be connected to the positive voltage and the black probe needs to be connected to the negative voltage or ground).



Figure 1. The measured voltage in this figure is 1.626 V DC.

#### Note:

1. Do not measure a voltage over 600 V, because there is a risk to damage the instrument circuit.
2. When measuring a high voltage circuit, pay attention not to touch any high voltage part of the circuit.

## 6.2 AC Voltage Measurement

1. Insert the black wire to "COM" and the red wire to  $V_{Hz} \cdot \Omega$  port.
2. Turn the rotary switch to AC and DC voltage measurement function.
3. Press the "SEL" key to select AC voltage measurement.
4. Connect the probes to the voltage that you want to measure, press "REL|HZ%" to switch the display between frequency and duty cycle measurement.



Figure 2. The measured voltage in this figure is 242.9 V AC.

### Note:

1. Do not measure a voltage over 600 Vrms, because there is a risk to damage the instrument circuit.
2. When measuring a high voltage circuit, pay attention not to touch any high voltage part of the circuit.

## 6.3 AC Current Measurement

1. Turn the rotary switch to the desired current range.
2. Insert the wire through which you want to measure the current into the current clamp.
3. Press the "SEL|HZ%" key to select AC current measurement.

**Note:** Both versions can measure AC current, but only **CL101C** can measure DC current.



**Figure 3.** The measured current in this figure is 0.130 A AC.

**Note:** If the range of the current to be measured is unknown, put the rotary switch to the highest range, then according to the value displayed, turn to the corresponding range.

## 6.4 DC Current Measurement

1. Turn the rotary switch to the desired current range.
2. Insert the wire through which you want to measure the current into the current clamp.
3. Press the "SEL" key to select DC current measurement.
4. Press and hold the REL|Hz% key, this will set the display to zero.

**Note:** Both versions can measure AC current, but only **CL101C** can measure DC current.



**Figure 4.** The measured current in this figure is 3.70 A DC.

If you want to measure a small current there is a method you can make many loops of the wire, like if you loop it 10 times you increase the magnetic field by 10 times and you read 10 times the real value.

Let us measure the current for a load by looping it 10 times.



Figure 5. The measured current in this figure is 4.90 A DC.

So the real value is:

$$\frac{4.90 A}{10} = 0.49 A DC$$

## 6.5 Resistance Measurement

1. Insert the black wire to "COM" and the red wire to  $VHz \cdot \Omega$  port.
2. Turn the rotary switch to Capacitance- Continuity-Resistance-Diode function  $\Omega$ .
3. Press the "SEL" key to select resistance measurement.



Figure 6. The measured resistance in this figure is 9.92 kΩ.



Figure 7. The measured resistance in this figure is 8.0 Ω.

**Note:**

1. When the input is open, the display will show "OL".
2. When measuring the on-line resistance, make sure that all the power of the circuit under test is turned off and all the capacitors are fully discharged.
3. Do not input voltage in the resistance test.
4. Do not touch the two test probes at the same time, because the resistance of your body will be added in parallel to the resistance that you want to measure.

## 6.6 Capacitance Measurement

1. Insert the black wire to "COM" and the red wire to  $VHz \cdot \Omega$  port.
2. Turn the rotary switch to Capacitance-Continuity-Resistance-Diode function  $\leftarrow \Omega$ .
3. Press the "SEL" key to select capacitance measurement.



Figure 8. The measured capacitance in this figure is 143.1 nF.



Figure 9. The measured capacitance in this figure is 35.62  $\mu\text{F}$ .

**Note:**

1. When the input is open, the display will show "0.000".
2. When measuring the on-line capacitor, make sure that all the power of the circuit under test is turned off and all the capacitors are fully discharged.
3. Do not input voltage in the capacitance test.
4. Do not touch the two test probes at the same time, because the capacitance of your body will be added in parallel to the capacitance that you want to measure.

## 6.7 Diode Test

1. Insert the black wire to "COM" and the red wire to VHz  $\rightarrow \Omega$  port.
2. Turn the rotary switch to Capacitance-Continuity-Resistance-Diode function  $\rightarrow \Omega$ .
3. Press the "SEL" key to select diode measurement.
4. Connect the black probe to the **cathode** and the red probe to the **anode**.

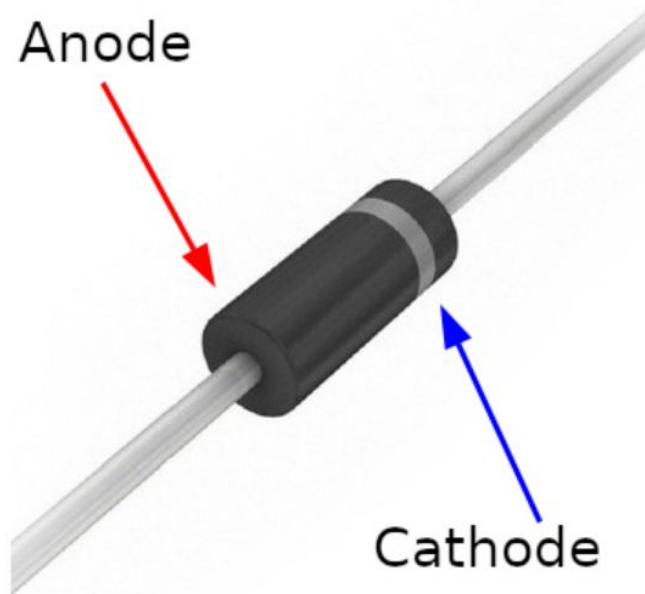

The display will show the approximate forward voltage drop.



Figure 10. The measured forward voltage in this figure is 0.541 V.



Figure 11. If you connect the probes incorrectly, the display will show "OL".



Figure 12. The measured forward voltage in this figure is 1.807 V.

## 6.8 Continuity Test

1. Insert the black wire to "COM" and the red wire to  $\text{VHz} \cdot \Omega$  port.
2. Turn the rotary switch to Capacitance-Continuity-Resistance-Diode function  $\text{C} \cdot \Omega$ .
3. Press the "SEL" key to select Continuity Test  $\text{C} \cdot \Omega$ .



Figure 13. If a conductor path is connected, the clamp meter will beep and the alarm indicator light will light up.



Figure 14. If a conductor path is broken the clamp meter will not beep.

## 6.9 Temperature measurement

1. Insert the black terminal of the thermocouple to "COM" and the red terminal of the thermocouple to VHz· $\Omega$  port.
2. Turn the rotary switch to **TEMP** measurement .
3. Press the " **SEL** " key to switch between degrees Celsius and Fahrenheit.



Figure 15. The measured temperature in this figure is 430 °C.



Figure 16. The measured temperature in this figure is 879 °F.

## 6.10 Frequency measurement

1. Insert the black wire to "COM" and the red wire to " VHz·Ω " port.
2. Turn the rotary switch to Frequency measurement - Duty cycle measurement (**Hz%**).
3. If you use **CL101B** version, press **SEL|Hz%** key to select Frequency measurement (**Hz**).  
For **CL101C** version,, press **REL|Hz%** key to select Frequency measurement (**Hz**).

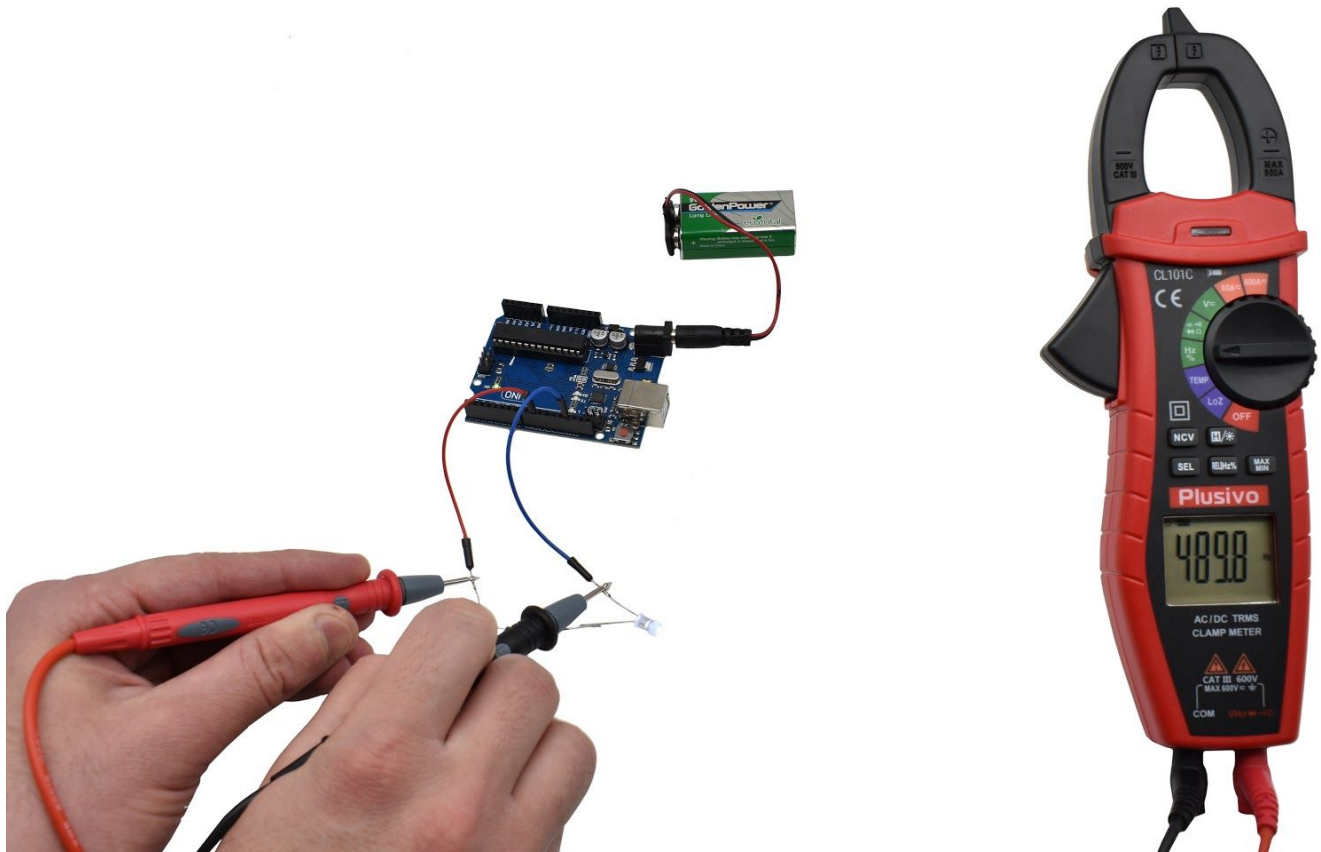

Figure 17. The measured frequency in this figure is 489.8 Hz.

## 6.11 Frequency measurement using the clamp

1. Turn the rotary switch to AC and DC voltage measurement function.
2. Press the "SEL" key to select AC voltage measurement.
3. If you use **CL101B** version, press **SEL|HZ%** key to select Frequency measurement (**Hz**).  
For **CL101C** version, press **REL|HZ%** key to select Frequency measurement (**Hz**).



Figure 18. The measured frequency in this figure is 50.08 Hz.

## 6.12 Duty cycle measurement

1. Insert the black wire to "COM" and the red wire to " VHz ·  $\Omega$  ".
2. Turn the rotary switch to Frequency measurement - Duty cycle measurement (**Hz%**).
3. If you use **CL101B** version press **SEL|HZ%** key to select Duty cycle measurement (**%**).  
For **CL101C** version, press **REL|HZ%** key to select Duty cycle measurement (**%**).

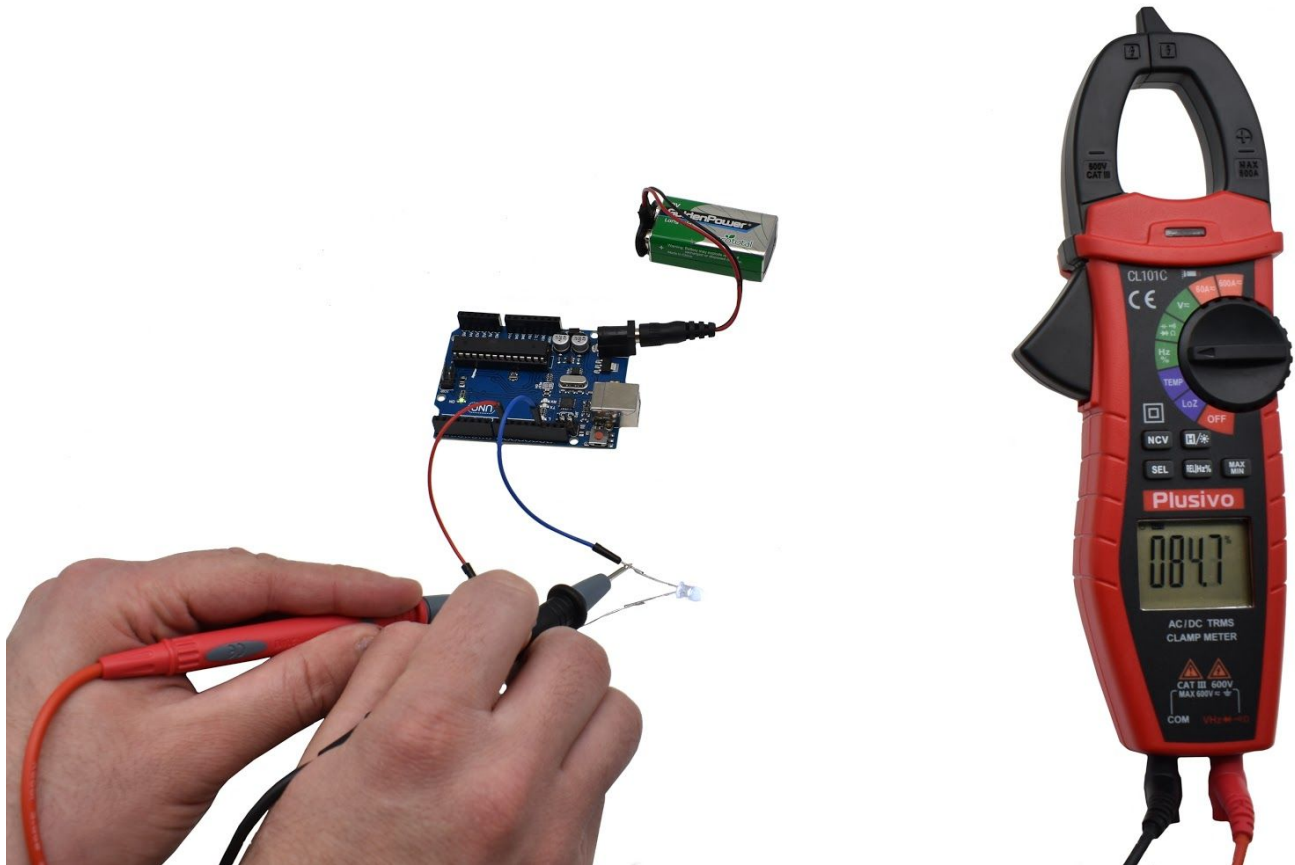



Figure 19. The measured duty cycle in this figure is 84.7 %.

## 6.13 MAX/MIN measurement

This method can be used to capture instantaneous minimum values or maximum values. During this measurement the clamp meter will capture the lowest value and the highest value in addition to calculating the differential between them.

1. Select what you want to measure.
2. Press the  key to switch between MAX, MIN and MAX-MIN.

We will measure a variable DC voltage as an example. We will measure DC voltage from 10V to 13V, and then we will switch between MAX, MIN and MAX-MIN values.

**Minimum value:**



Figure 20. The MIN voltage in this figure is 10.11 V DC.

Maximum value:



Figure 21. The MAX voltage in this figure is 13.06 V DC.

Maximum value - Minimum value:



Figure 22. The MAX-MIN voltage in this figure is 2.95 V DC.

## 6.14 REL (relative) measurement

1. Select what you want to measure.
2. Press and hold on Relative measurement key  .

Clamp meter will store the instantaneous measurement as a reference value, and sets the display to zero.

**Note:** This function is only available in **CL101C** version.

We will measure DC voltage as an example:

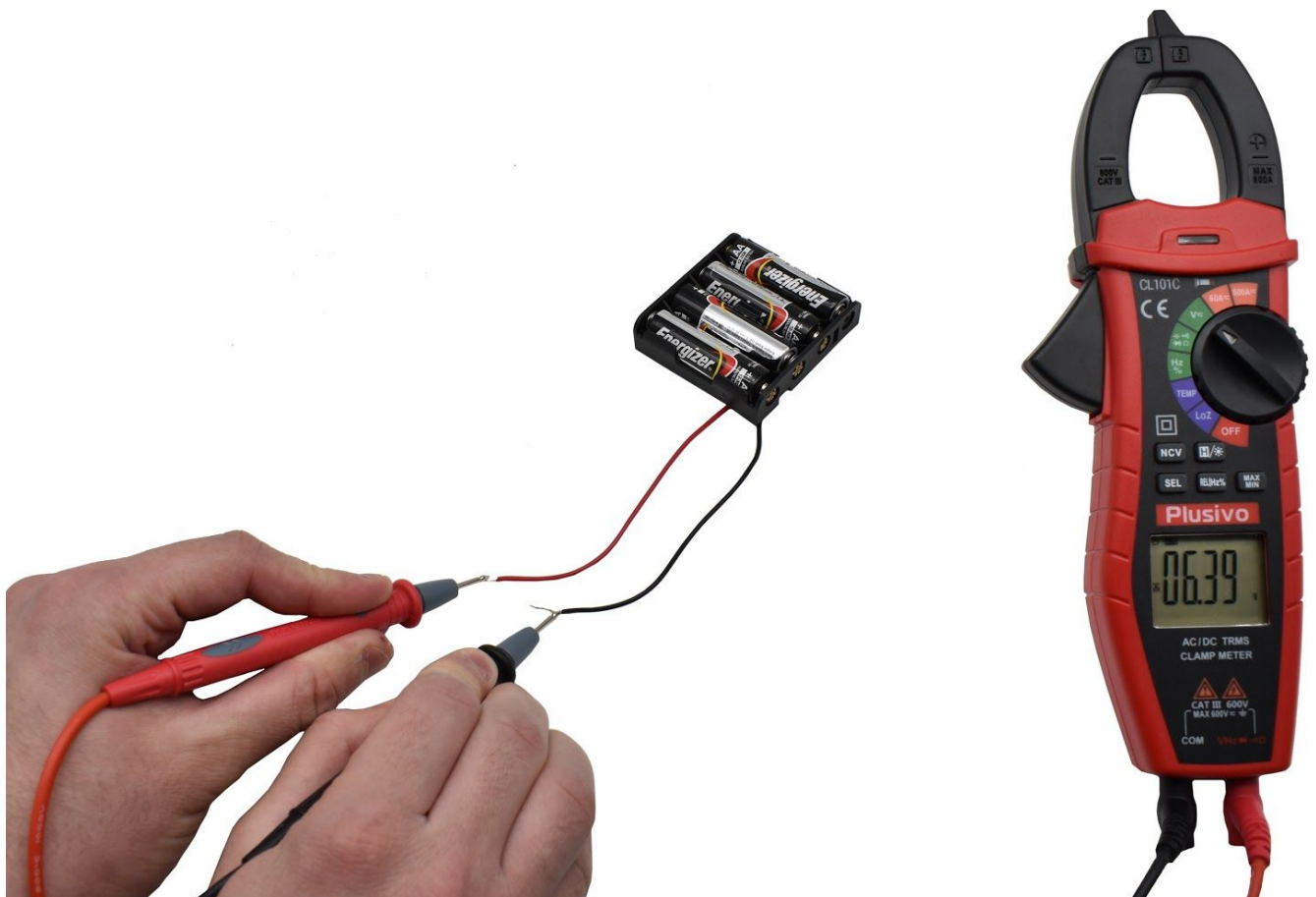
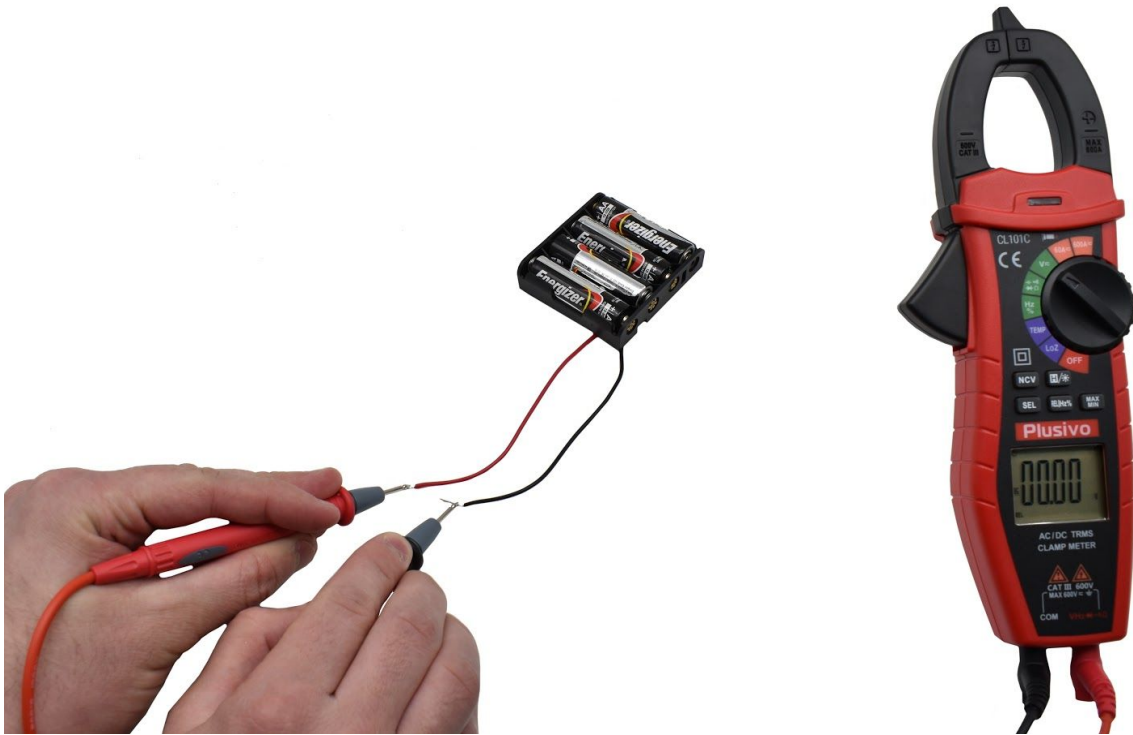

Figure 23. The measured voltage in this figure is 6.39 V DC.

Then Press and hold the Relative measurement key .



**Figure 24. The measured voltage in this figure is 0 V DC.**

The value of the voltage is stored now as a relative value, if we leave the probes the clamp meter will show a minus value.



**Figure 25. The measured voltage in this figure is -6.38 V DC.**

Then let's measure a 9V battery.



**Figure 26. The measured voltage in this figure is 1.90 V DC.**

This value is:

$$1.90 \text{ V} + 6.38 \text{ V} = 8.28 \text{ V}$$

## 6.15 LoZ (low impedance) measurement

During voltage measurement, the input impedance of the clamp meter is too high (more than 6 M $\Omega$ ) so it will take a very little current from the measuring point. So it is important to measure very small current, because the input impedance is too high.

But if you will try to measure non-energized wires but they are close to energized wire, the energized wire will generate a magnetic field. So a small voltage will be generated in the non-energized wire and they call this voltage (**ghost voltage**).

If we measure this voltage using normal AC voltage measurement, the clamp meter will show some volts, according to the high impedance input. In this case we need to use LoZ measurement, the impedance of the input is around 300 k $\Omega$ , so during the measurement it will take more current to measure the voltage, this way you can judge the voltage if it is real, or just a (**ghost voltage**).

Now let us measure the voltage using normal AC voltage measurement:

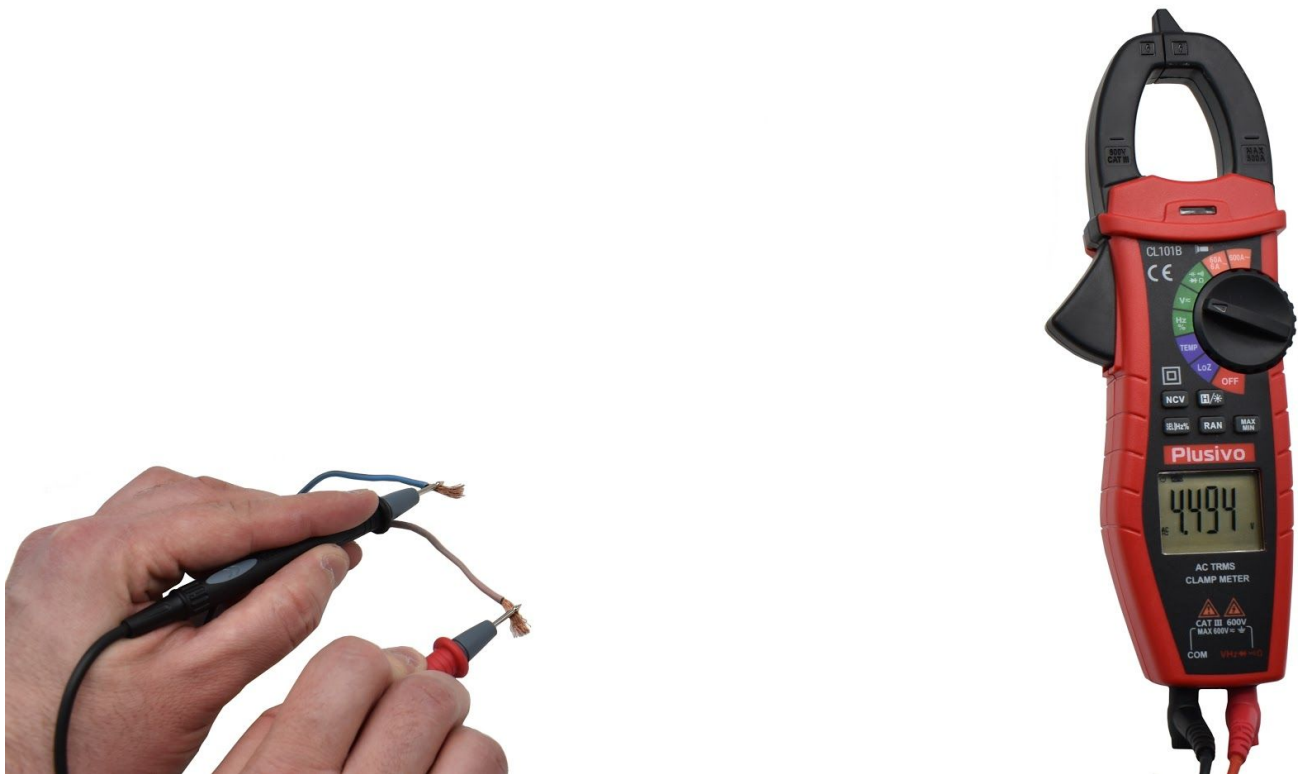

Figure 27. The measured voltage in this figure is 4.494 V AC.

Let us measure the same voltage using LoZ measurement:



Figure 28. The measured voltage in this figure is 0.0 V AC.

**Note:** In low impedance measurement mode the longest measurement time shall not exceed 1 minute.

## 6.16 NCV Detection

The NCV function can be used with the rotary switch turned to any position. The instrument can detect whether the conductor being measured carries a voltage higher than 90 V AC. For using the NCV function, press the "NCV" key to display EF and bring the NCV sensor close to the conductor under test.

The NCV sensor is located at the tip of the current clamp, when the instrument detects AC voltage the buzzer gets activated and the NCV alarm light will flash.



Figure 29. Clamp meter detects AC voltage.

**Note:** Even if there's no alarm indication, voltage may still exist. Do not depend on the non contact voltage detector for judging on whether there's voltage or not in a wire. The detection may be impacted by various factors like different socket designs, different insulation materials, insulation thickness, etc.

## 7. Basic Concepts

### 7.1 Ohm's Law

It is a law that illustrates the relationship between the voltage, the current, and the resistance.

$$V = I \cdot R$$

$$R = \frac{V}{I}$$

$$I = \frac{V}{R}$$

I is the current through the resistor.

V is the voltage around the resistor.

R is the resistance.

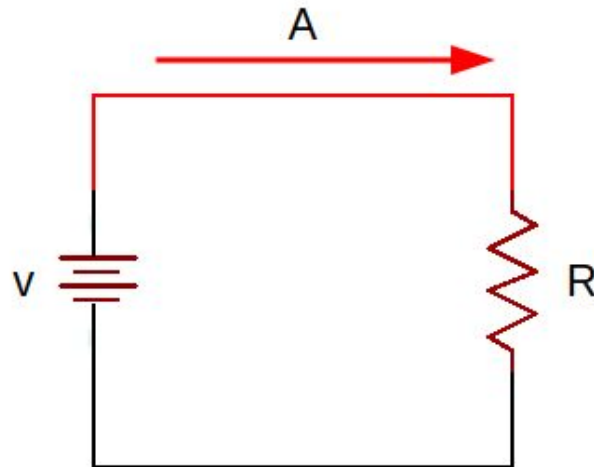

#### 7.1.1 Example

Calculate the current in this circuit.

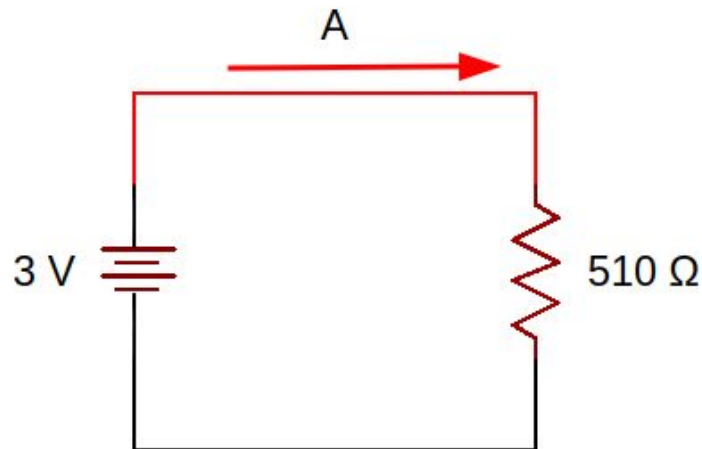

Simply, we can use Ohm's law:  $I = \frac{V}{R}$

$$\frac{3 V}{510 \Omega} = 0.00588 A = 5.88 mA$$

Let us build this circuit in reality, and measure the voltage and the resistance.

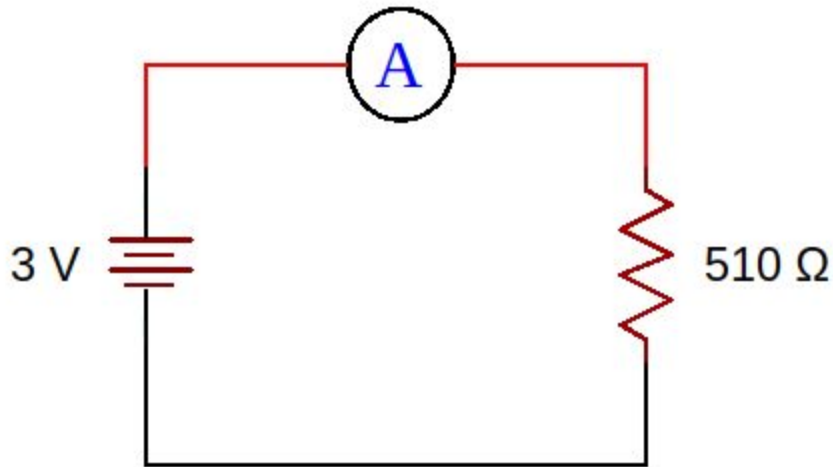

If we measure the resistance on the resistor:



Figure 30. The measured resistance in this figure is 510 Ω.

**Note:**

Disconnect the battery when measuring the resistance, otherwise, the clamp meter may be damaged.

If we measure the voltage around the resistor:

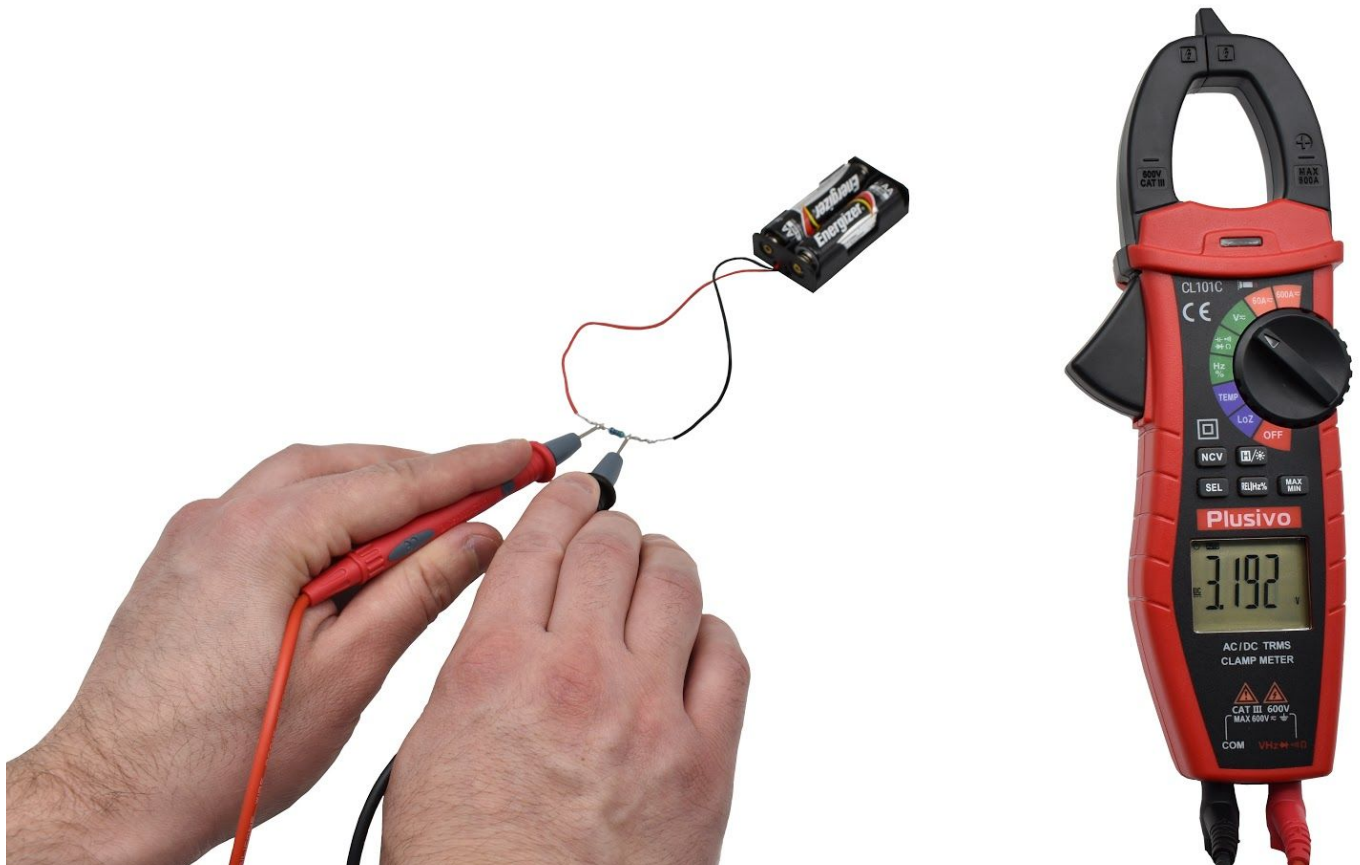

Figure 31. The measured voltage in this figure is 3.192 V DC.

If we calculate the measured values:  $\frac{3.192 V}{510 \Omega} = 6.26 mA$

## 7.2 Joule's Law for Electrical Power

Electric power is the rate of the emitting power from a resistor per unit time, the unit of power is watt.

$$P = I \cdot V$$
$$P = I^2 \cdot R$$
$$P = \frac{V^2}{R}$$

**P** is the power on the resistor.

**I** is the current through the resistor.

**V** is the voltage around the resistor.

**R** is the resistance.

**Note:** There are many types of emitting power, it may be a rotary power, light, heat, etc.

### 7.2.1 Example

Calculate the power on the resistor.

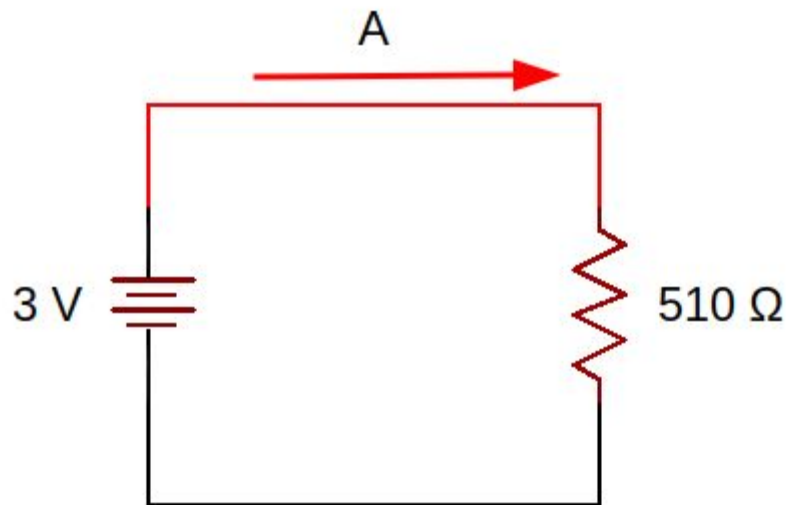

To calculate the power on the resistor, we need any two values of these: **Voltage**, **Current** or **Resistance**.

In our example, we have the voltage and the resistance, so we can use this formula:

$$P = \frac{V^2}{R}$$
$$\frac{(3 V)^2}{510 \Omega} = 0.0176 W = 17.6 mW$$

Let us see what we will get if we built this circuit in reality and calculate the power using the clamp meter.



Figure 32. The measured resistance in this figure is 510 Ω.

**Note:**

Disconnect the battery when measuring the resistance, otherwise, the clamp meter may be damaged.



Figure 33. The measured voltage in this figure is 3.192 V DC.

So if we calculate the new values:  $\frac{(3.192 V)^2}{510 \Omega} = 19.98 mW$

We can count on our calculation “  $\frac{(3 V)^2}{510 \Omega} = 0.0176 W = 17.6 mW$  ” because **17.6 mW** is almost equal to **19.98 mW**.

## 7.3 Kirchhoff's Law

### 7.3.1 Kirchhoff's Current Law

Currents entering the node equals currents leaving the node.

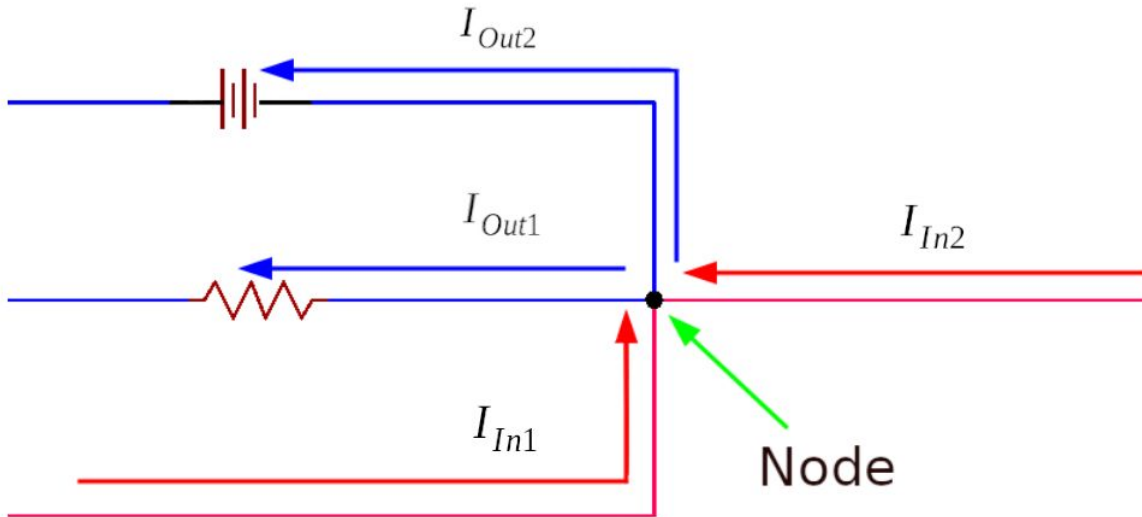

### 7.3.2 Kirchhoff's Voltage Law

The sum of all the voltages around the loop is equal to zero.

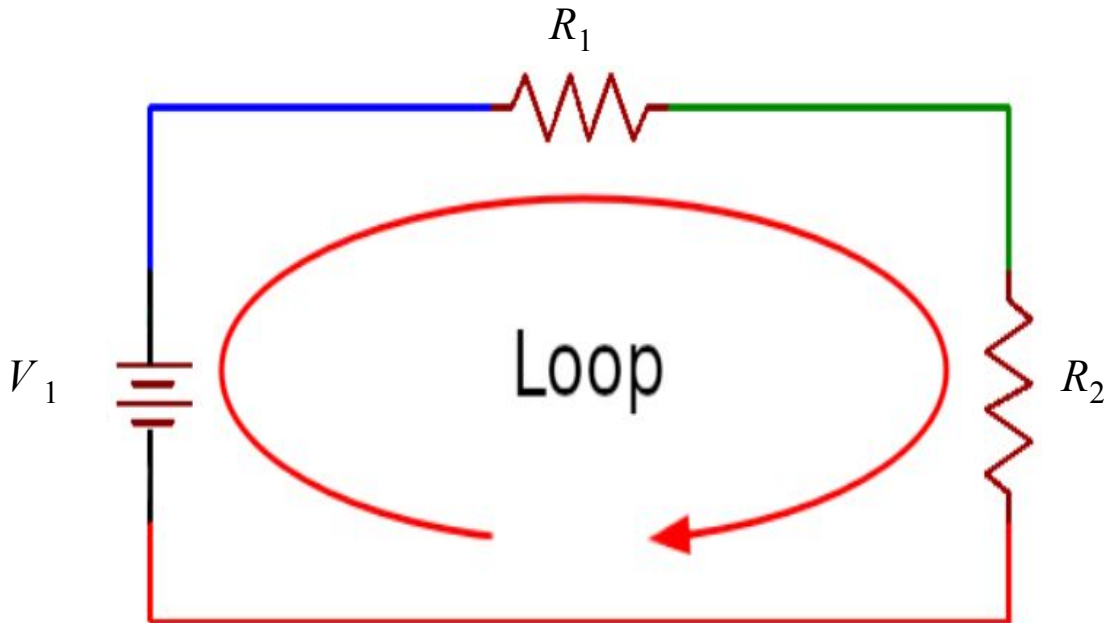

## 7.3.3 Example

Calculate the voltage around the resistors.

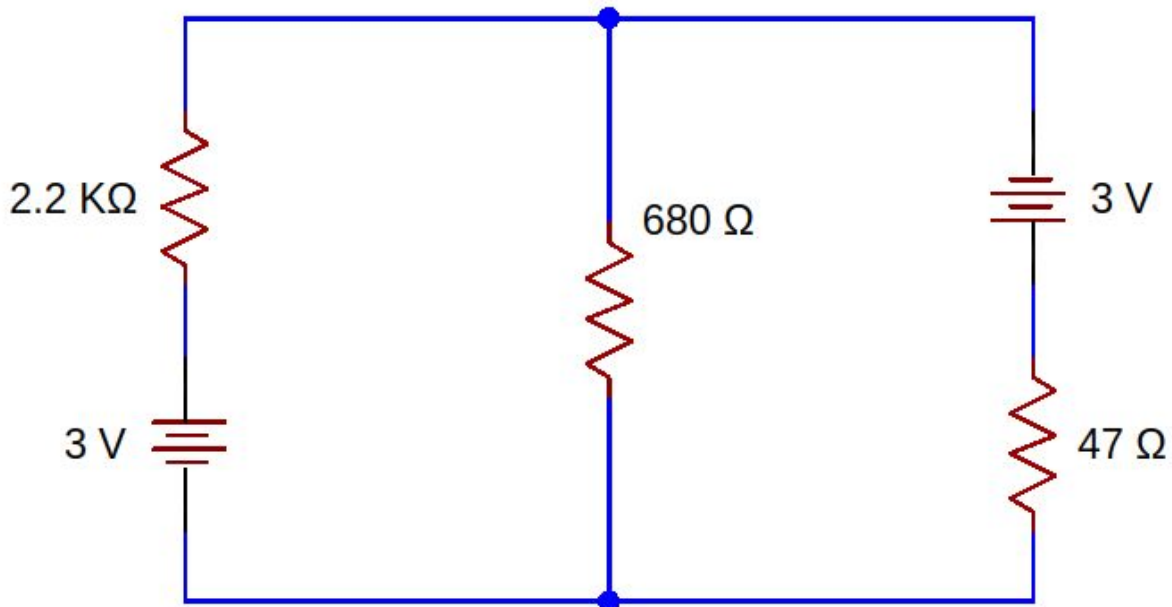

In this case, we are going to use Kirchhoff's law, we need to suppose the paths for the current to use Kirchhoff's current law, and we need to suppose two loops to use Kirchhoff's voltage law.

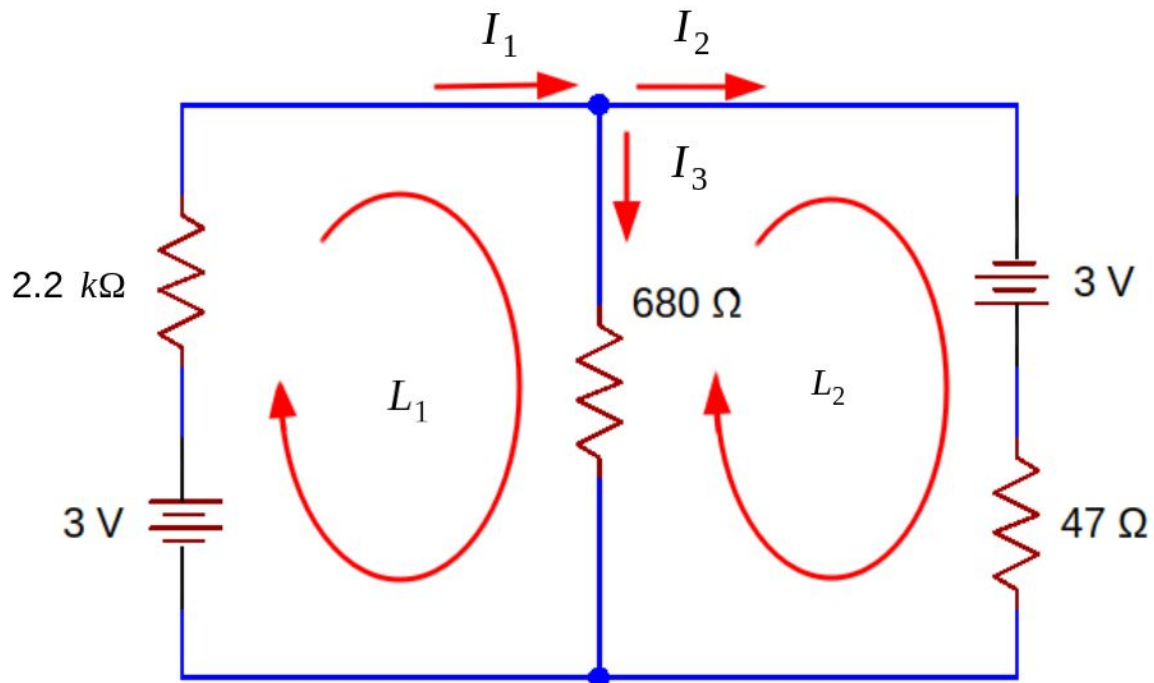

To use Kirchhoff's voltage law, we need to know some rules, for example, in  $L_1$  if the loop passes the battery from - to + we write it in the equation (+3 V), but if the loop passes the battery from + to - we write it in the equation (-3 V). Let us take 2.2 kΩ resistor as an example, if the loop passes the resistor in the same direction with the current we write it ( $- 2.2 \text{ k}\Omega \cdot I_1$ ), but if the loop passes the resistor in the opposite direction with the current we write it ( $+ 2.2 \text{ k}\Omega \cdot I_1$ ).

We get this equation from  $L_1$ .

$$\text{Equation 1: } 3 V - (I_1 \cdot 2.2 k\Omega) - (I_3 \cdot 680 \Omega) = 0 V$$

We get this equation from  $L_2$ .

$$\text{Equation 2: } (I_3 \cdot 680 \Omega) + 3 V - (I_2 \cdot 47 \Omega) = 0 V$$

We get this equation from **the node**.

$$\text{Equation 3: } I_1 = I_2 + I_3$$

Now, let us do some math to calculate  $I_1$ ,  $I_2$  and  $I_3$ .

$$\text{Equation 1: } 3 V - (I_1 \cdot 2.2 k\Omega) - (I_3 \cdot 680 \Omega) = 0 V$$

$$3 V - (I_3 \cdot 680 \Omega) = I_1 \cdot 2200 \Omega$$

$$I_1 = \frac{3 V}{2200 \Omega} - \frac{I_3 \cdot 680 \Omega}{2200 \Omega}$$

$$I_1 = 0.001363 A - (I_3 \cdot 0.3091) \rightarrow \text{This becomes equation 4}$$

$$\text{Equation 2: } (I_3 \cdot 680 \Omega) + 3 V - (I_2 \cdot 47 \Omega) = 0 V$$

$$I_2 \cdot 47 \Omega = (I_3 \cdot 680 \Omega) + 3 V$$

$$I_2 = \frac{I_3 \cdot 680 \Omega}{47 \Omega} + \frac{3 V}{47 \Omega}$$

$$I_2 = (I_3 \cdot 14.468) + 0.0638 A \rightarrow \text{This becomes equation 5}$$

$$\text{Equation 4: } I_1 = 0.001363 A - (I_3 \cdot 0.3091)$$

$$\text{Equation 5: } I_2 = (I_3 \cdot 14.468) + 0.0638 A$$

From **Equation 3:**  $I_1 = I_2 + I_3$ , we will use the derived  $I_1$  and  $I_2$  from previous calculation to get  $I_3$ , thus,

$$0.001363 A - (I_3 \cdot 0.3091) = (I_3 \cdot 14.468) + 0.0638 A + I_3$$

$$- I_3 \cdot 0.3091 = (I_3 \cdot 14.468) + 0.0638 A - 0.001363 A + I_3$$

$$- I_3 \cdot 0.3091 = (I_3 \cdot 14.468) + 0.062437 + I_3$$

$$- 0.062437 = (I_3 \cdot 0.3091) + (I_3 \cdot 14.468) + I_3$$

$$- 0.062437 = 15.7771 \cdot I_3$$

$$I_3 = - 0.003957 A$$

$$\text{Equation 4: } I_1 = 0.001363 A - (I_3 \cdot 0.3091)$$

$$I_1 = 0.001363 A - (-0.003957 A \cdot 0.3091)$$

$$I_1 = 0.001363 A + 0.001223 A$$

$$I_1 = 0.002586 A$$

$$\text{Equation 5: } I_2 = (I_3 \cdot 14.468) + 0.0638 A$$

$$I_2 = (-0.003957 A \cdot 14.468) + 0.0638 A$$

$$I_2 = -0.05725 A + 0.0638 A$$

$$I_2 = 0.00655 \text{ A}$$

Do not forget that we have supposed the directions of the currents, in the final answer if we get a positive answer, like  $I_1$  and  $I_2$  the direction we have supposed is true, but if we get a negative answer, like  $I_3$  the direction we have supposed is wrong, so we must reverse it.

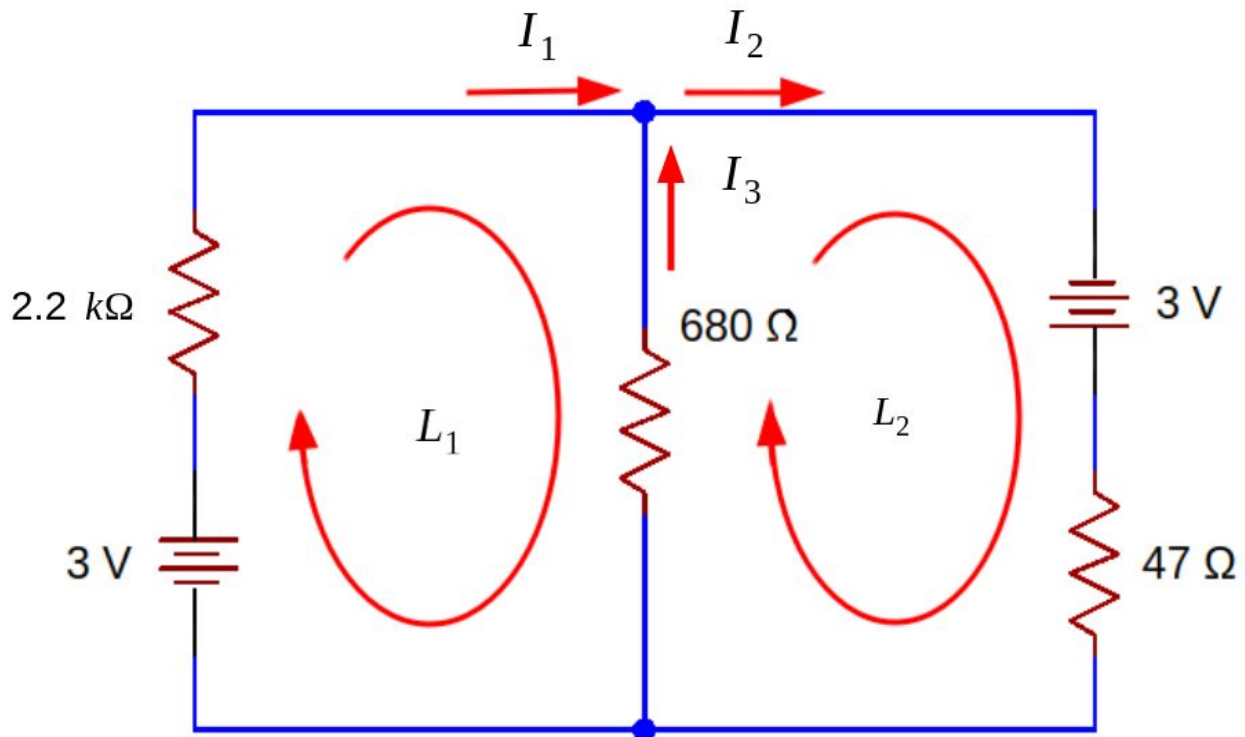

The equation  $I_1 = I_2 + I_3$  will be  $I_2 = I_1 + I_3$

Now, it is easy to calculate the voltage on the resistors using Ohm's law:  $V = I \cdot R$

The voltage on 2.2 kΩ

$$\begin{aligned} V &= I_1 \cdot 2.2 \text{ k}\Omega \\ V &= 0.002586 \cdot 2200 \Omega \\ V &= 5.7 \text{ V} \end{aligned}$$

The voltage on 680 Ω

$$\begin{aligned} V &= I_3 \cdot 680 \Omega \\ V &= 0.003957 \cdot 680 \Omega \\ V &= 2.7 \text{ V} \end{aligned}$$

The voltage on 47 Ω

$$\begin{aligned} V &= I_2 \cdot 47 \Omega \\ V &= 0.00655 \text{ A} \cdot 47 \Omega \\ V &= 0.3 \text{ V} \end{aligned}$$

Now, let us make this circuit in reality and measure the voltage around the resistors using the clamp meter.

The measured voltage around the 2.2 k $\Omega$  resistor is 6.061 V.

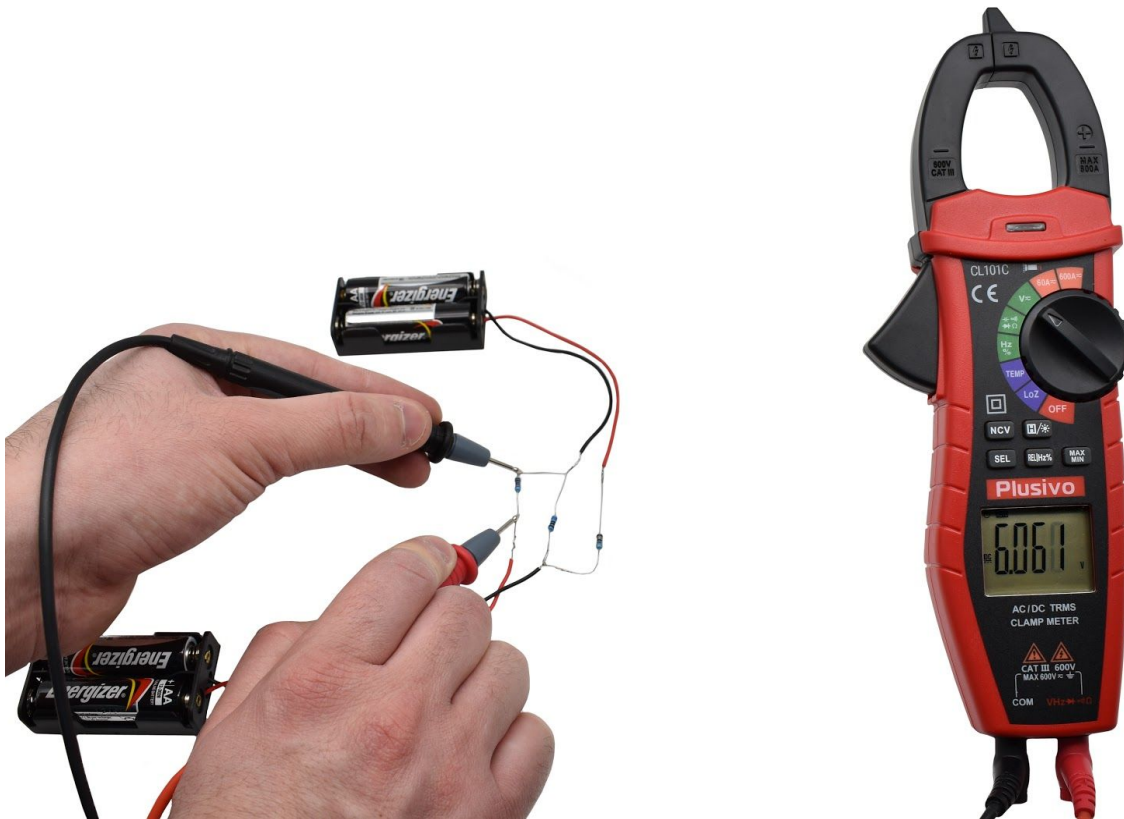

**Figure 34. The measured voltage in this figure is 6.061 V DC.**

The measured voltage around the 680  $\Omega$  resistor is 2.862 V.

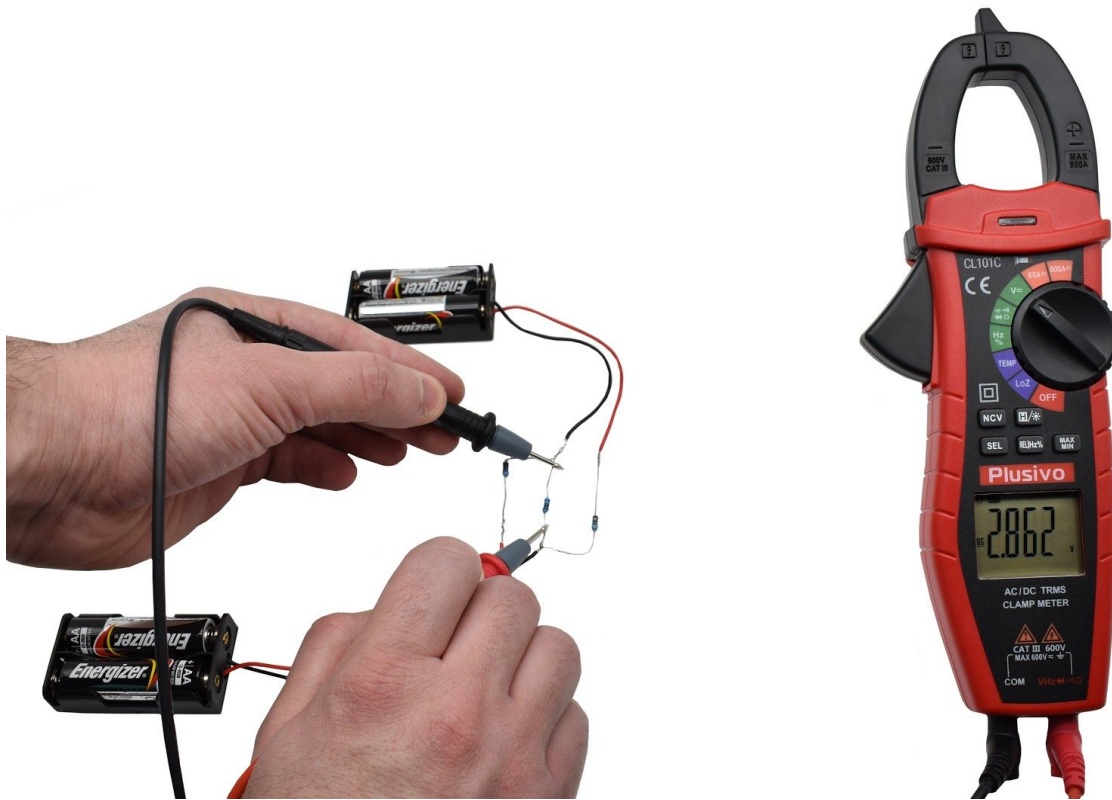

**Figure 35. The measured voltage in this figure is 2.862 V DC.**  
The measured voltage around the 47  $\Omega$  resistor is 328.4 mV.

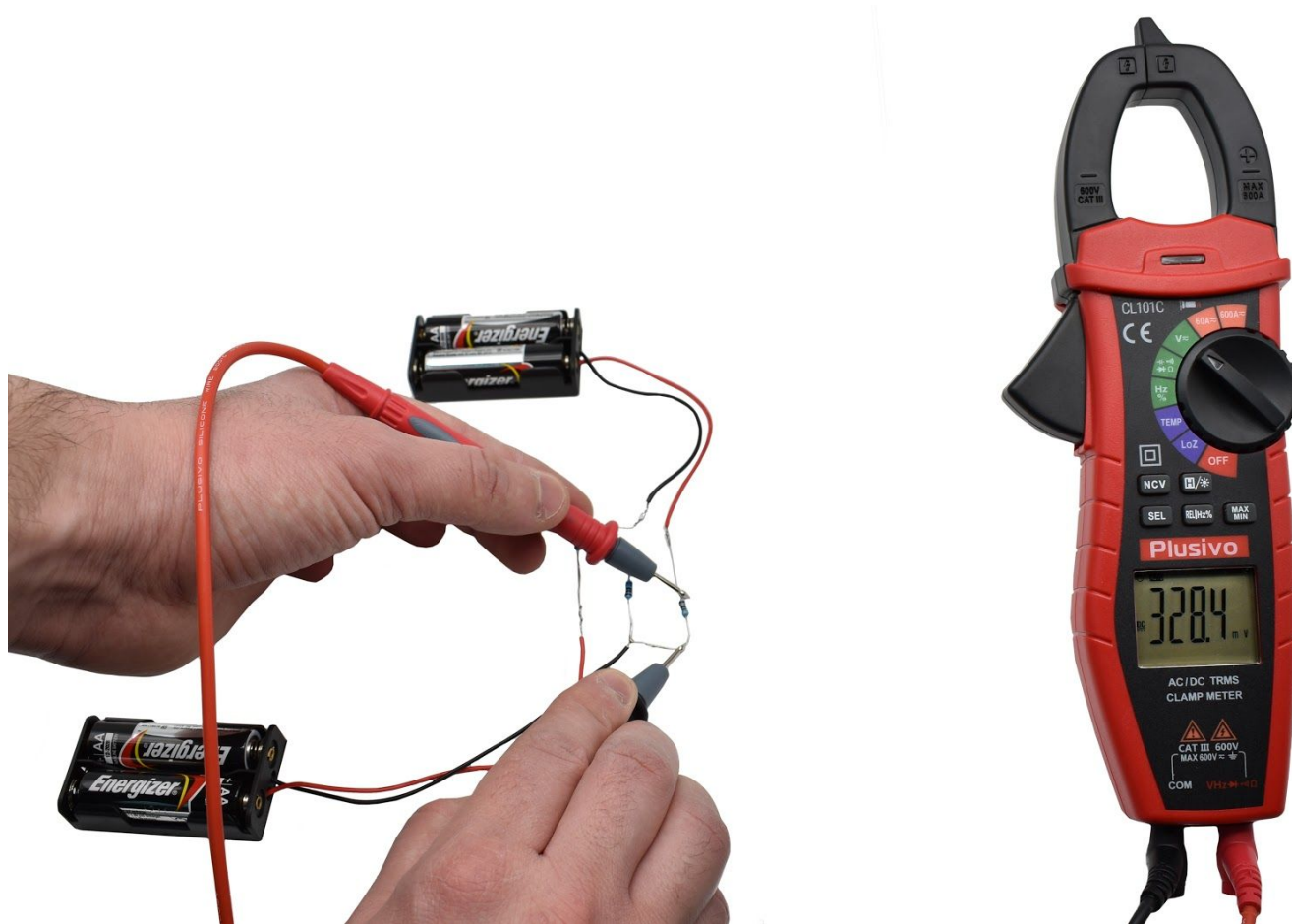
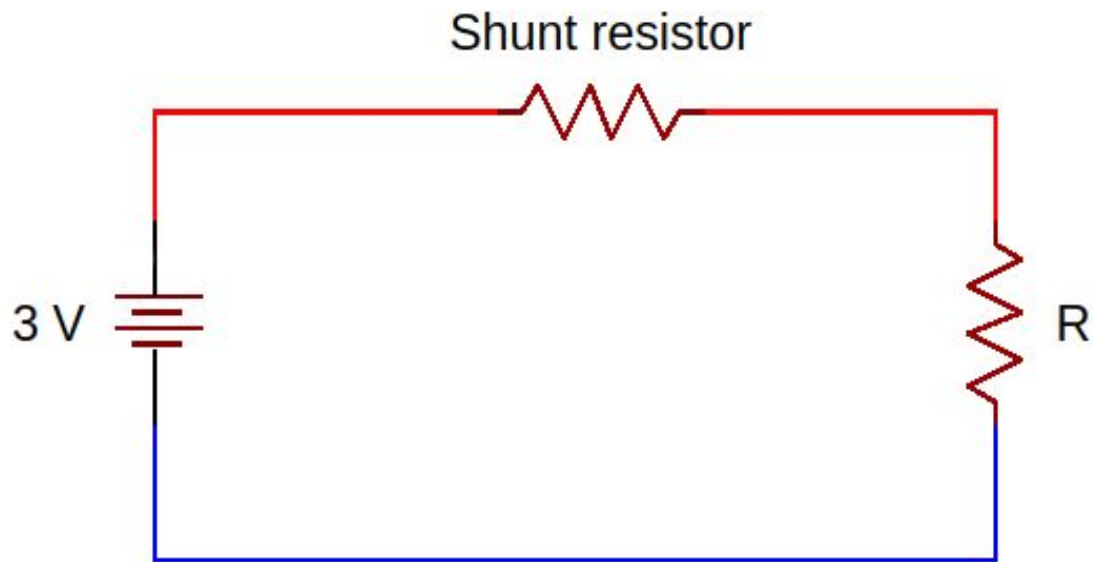

Figure 36. The measured voltage in this figure is 328.4 mV DC.

So we can count on our calculation, we will always find these small differences between the calculations and the real measurements because of the tolerance of the components.

## 7.4 Shunt resistor

It is a way to measure the current through a bath in the circuit using a small value resistor, we cut the circuit and connect it again using the shunt resistor, in most cases, it should be a high power resistor to handle the current passing through it.



So depending on ohm's law " $V = I \cdot R$ ", we have a shunt resistor, and we have a current passing through it, so the voltage will be generated around it, and then we will measure this voltage using the clamp meter, this way we have converted the current into voltage.

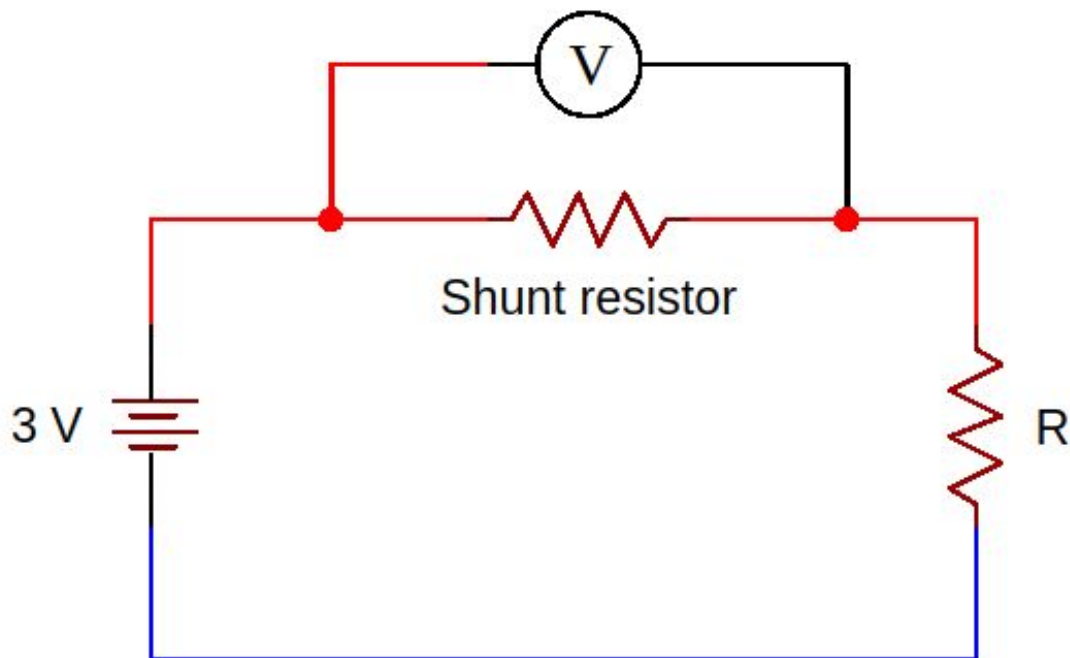

### 7.4.1 Example

In this circuit, we are going to use a  $8 \Omega$  resistor as a shunt, calculate the current using Ohm's law.

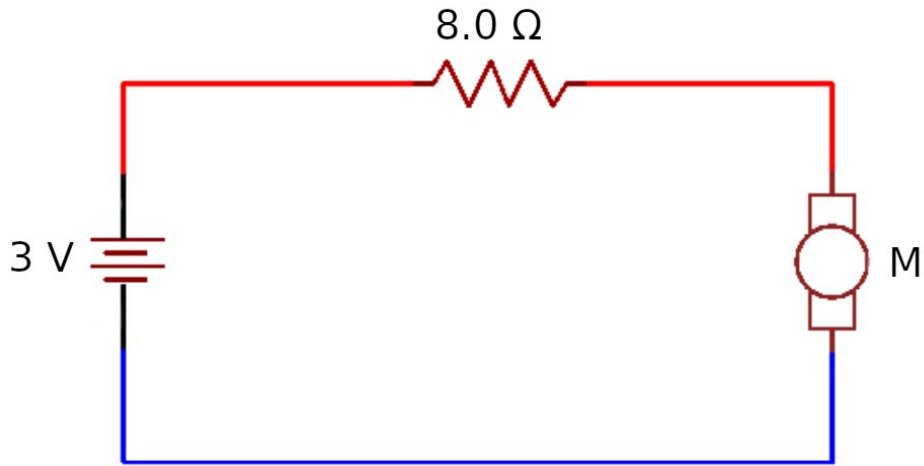

**Figure 37. The measured resistor in this figure is 8.0 Ω.**

Now, we need to measure the voltage around the 8 Ω shunt resistor using the clamp meter.



Figure 38. The measured voltage in this figure is 446.7 mV DC.

Using Ohm's law " $V = I \cdot R$ "

$$0.4467 V = I \cdot 8 \Omega$$

$$I = \frac{0.4467 V}{8 \Omega} = 0.0558 A = 55.8 mA$$

## 7.5 Choosing the Right Resistor for an LED

To calculate the resistor for an LED, we need to know the forward voltage for the LED. LEDs are different from the resistors, we need to limit the current passing through it because it does not work on Ohm's law.

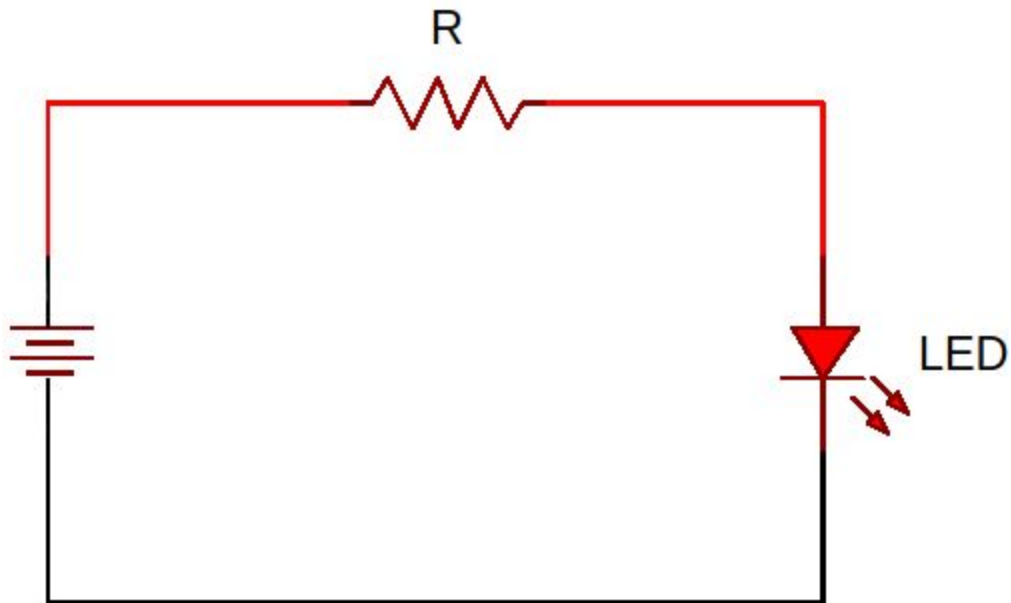

We need to know the voltage around the LED. Usually, a 5 mm LED needs 15 - 30 mA to be in good lighting, after knowing the forward voltage for the LED, it is easy to calculate the resistance.

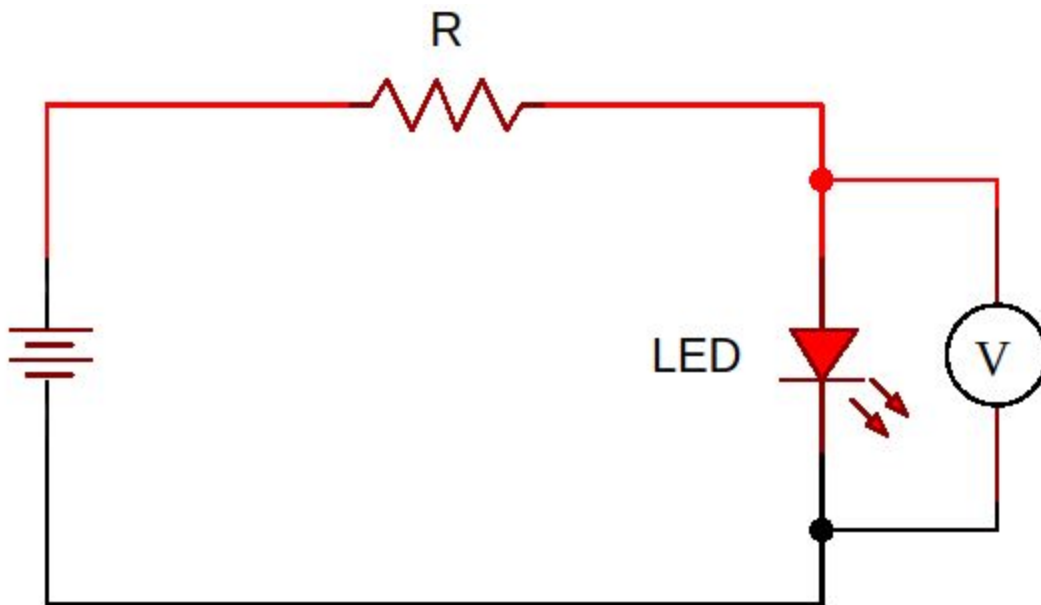

We can measure the forward voltage for the LED using the diode test function.

## 7.5.1 Example

Calculate the resistance in the following circuit for a red LED to make it consume around 20 mA.

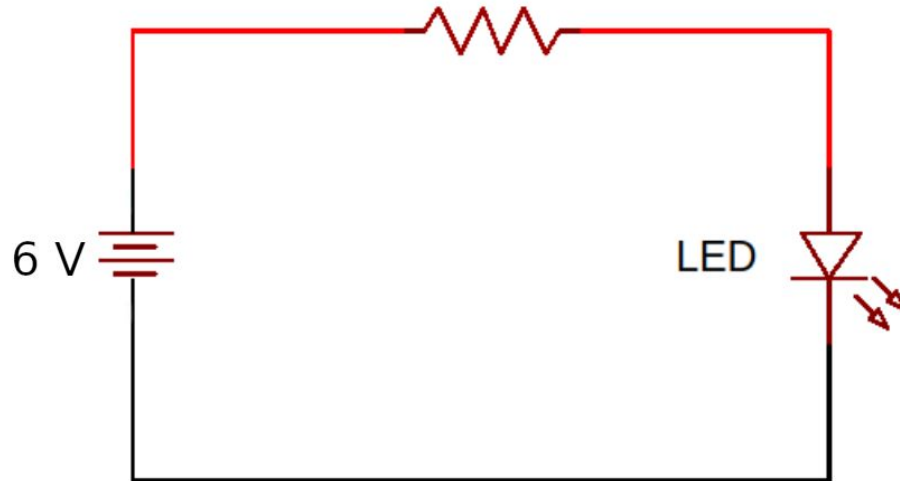

We need to measure the forward voltage:



Figure 39. The measured forward voltage in this figure is 1.807 V.

Now, let us calculate the value of the resistor. We have a **6 V** battery, the voltage on the LED is **1.807 V** so the voltage on the resistor is:  $6 V - 1.807 V = 4.193 V$

Now, let us use Ohm's law:  $R = \frac{V}{I}$

$$R = \frac{4.193 V}{20 mA} = 209.65 \Omega$$

And the closest standard value is 200  $\Omega$ .

## 7.6 Measuring Internal Resistance of a Battery

We need to follow these steps to measure the internal resistance of a battery using the clamp meter. First, we need to measure the voltage of the battery.

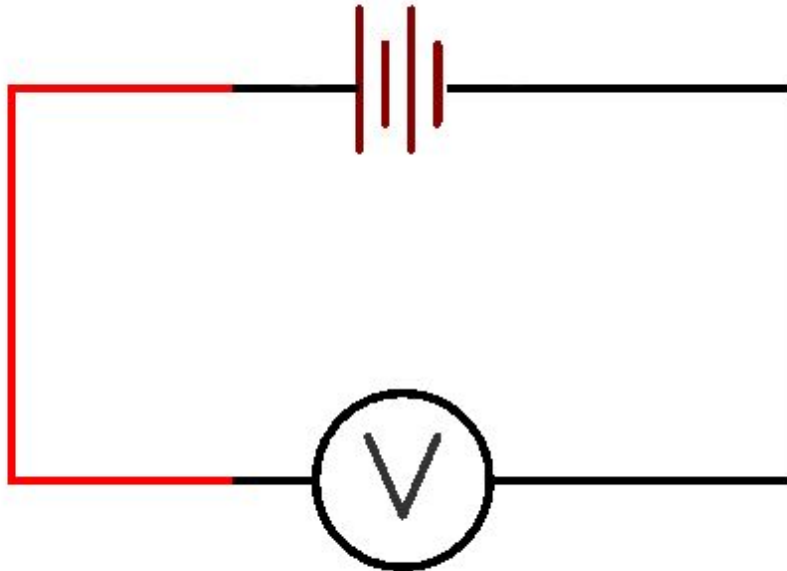

Second, we connect a resistor with the battery and measure its voltage.

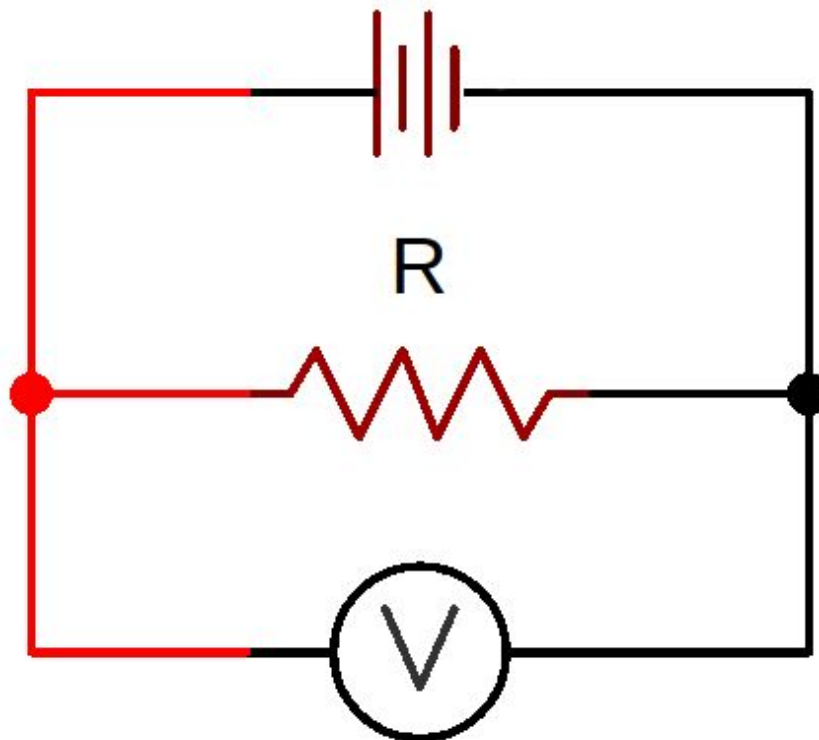

Third, we will do some calculations using Ohm's law.

- Calculate the current passing through the resistor:  $\frac{R_V}{R} = I$
- Subtract the voltage of the battery from the voltage on the resistor:  $B_V - R_V = B_{RV}$
- Now, we have the current and the voltage on the internal resistance, so we can calculate the value of the internal resistor:  $\frac{V}{I} = I_{BR}$

## 7.6.1 Example

To measure the internal resistance of a 9 V battery, we need to measure the voltage of the battery first.

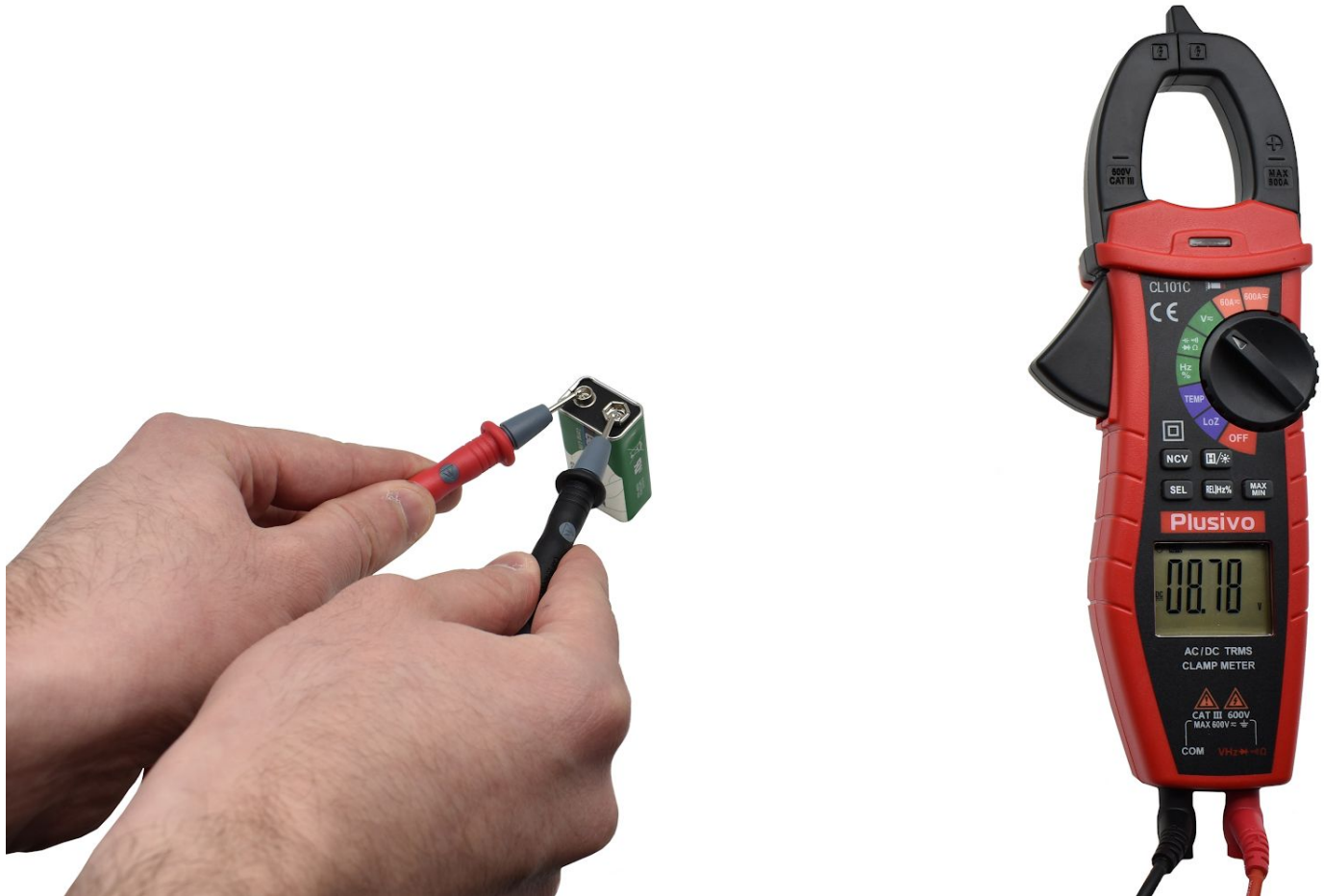

**Figure 40.** The measured voltage in this figure is 8.78 V DC.

Second, we connect a resistor with the battery and measure its voltage, in our case we will connect a 680  $\Omega$  resistor.



Figure 41. The measured voltage in this figure is 8.30 V DC.

Third, we will do some calculations using Ohm's law.

- Calculate the current passing through the resistor:  $\frac{R_V}{R} = I$

$$\frac{8.30 V}{680 \Omega} = 0.0122 A = 12.2 mA$$

- Subtract the voltage of the battery from the voltage of the resistor:  $B_V - R_V = B_{RV}$

$$8.78 V - 8.30 V = 0.48 V$$

- Now, we have the current and the voltage on the internal resistance, so we can calculate the value of the internal resistor:  $\frac{V}{I} = I_{BR}$

$$\frac{0.48 V}{0.0122 A} = 39.34 \Omega$$

## 7.7 Testing Some Components Using clamp meter

In this section, we are going to test some components using a clamp meter.

### 7.7.1 Potentiometer Test

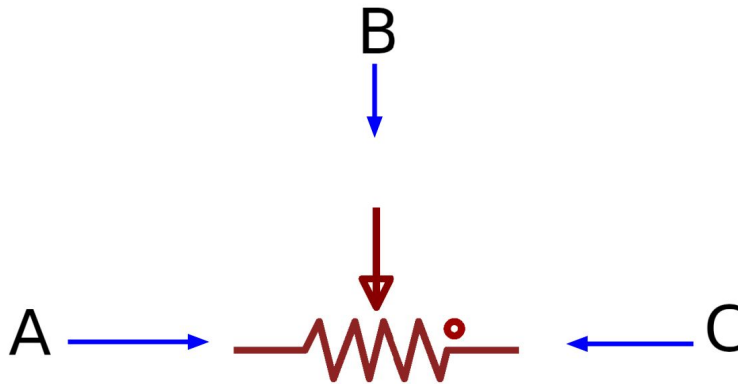

First, we need to measure the resistance between A - C.



Figure 42. The measured resistance in this figure is 47.15 kΩ.

And then we measure the resistance between A - B and B - C, the sum of the two values must be equal to A - C.



Figure 43. The measured resistance in this figure is 11.97 kΩ.



Figure 44. The measured resistance in this figure is 35.89 kΩ.

$11.97\text{ k}\Omega + 35.89\text{ k}\Omega = 47.86\text{ k}\Omega$ , which is almost equal to  $47.15\text{ k}\Omega$

## 7.7.2 BJT Transistor Test

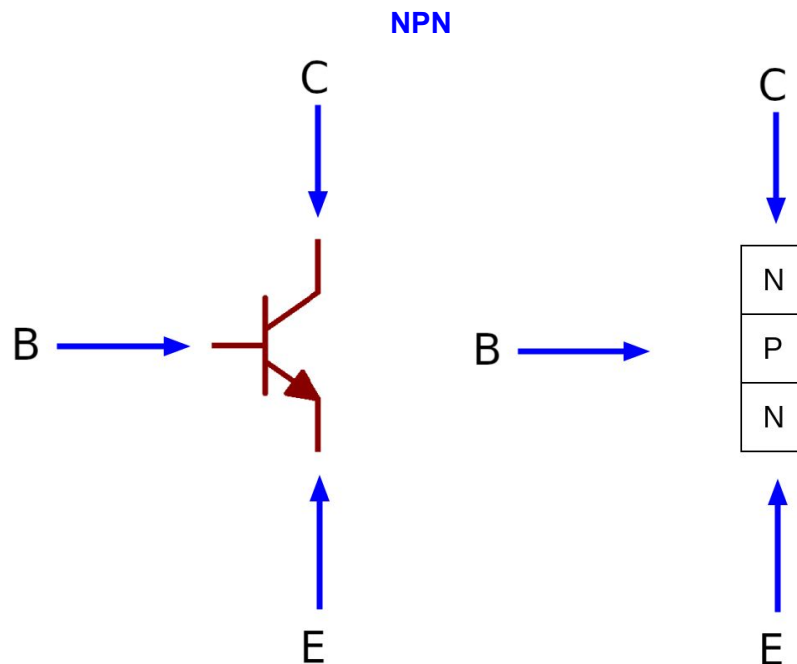

The NPN Type consists of two N-Regions separated by a P-Region, so we can suppose a diode between B - C and between B - E.

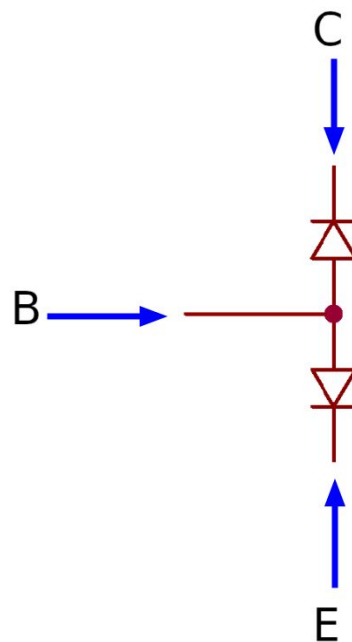

Now, we can test the NPN transistor as 2 diodes. To test the first diode (B - C), we need to connect the red probe to the anode which is the base of the transistor and connect the black probe to the cathode which is the collector of the transistor.

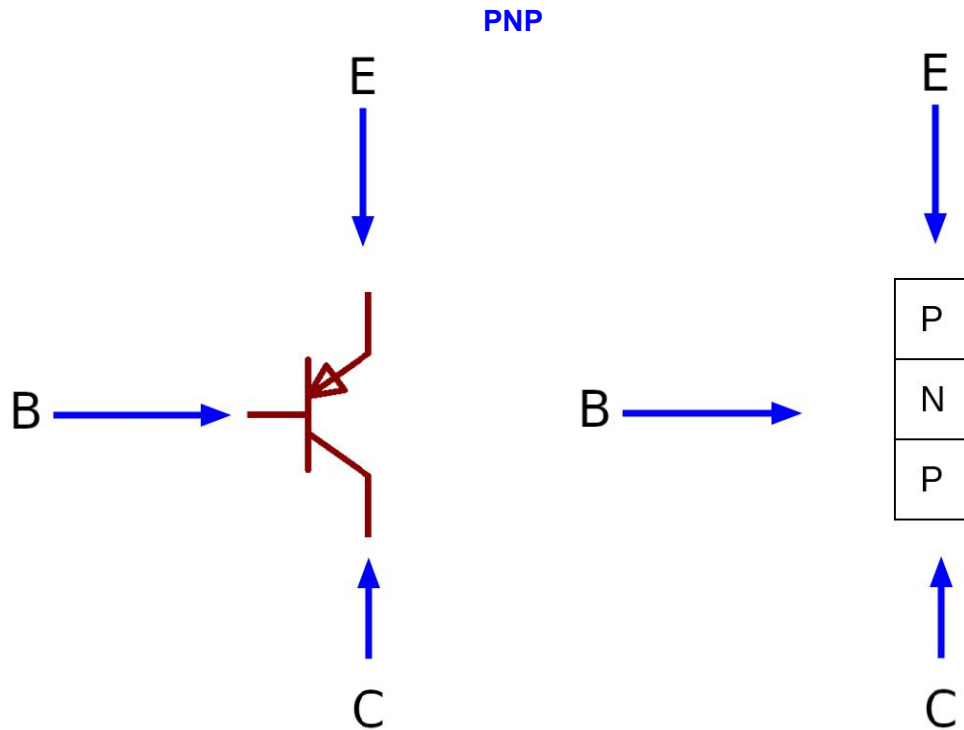

**Figure 45. The measured forward voltage in this figure is 0.651 V.**

To test the second diode (B - E), we need to connect the red probe to the anode which is the base of the transistor and connect the black probe to the cathode which is the emitter of the transistor.



**Figure 46. The measured forward voltage in this figure is 0.652 V.**



The PNP type consists of two P-Regions separated by N-Region, so we can suppose a diode between B - C and between B - E.

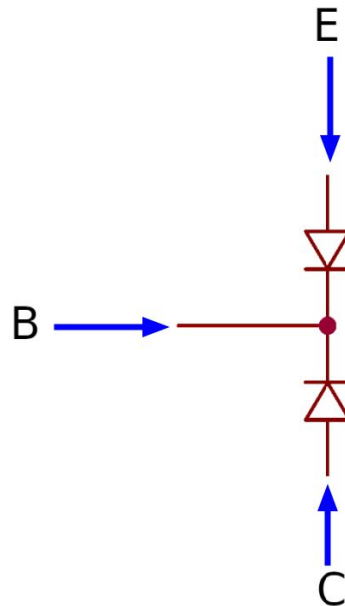

Now, we can test the PNP transistor as 2 diodes. To test the first diode (B - E), we need to connect the black probe to the cathode which is the base of the transistor and connect the red probe to the anode which is the emitter of the transistor.



**Figure 47. The measured forward voltage in this figure is 0.643 V.**

To test the second diode (B - C), we need to connect the black probe to the cathode which is the base of the transistor and connect the red probe to the anode which is the collector of the transistor.



**Figure 48. The measured forward voltage in this figure is 0.645 V.**